

User & Installation Manual

LT-300 GNSS Receiver

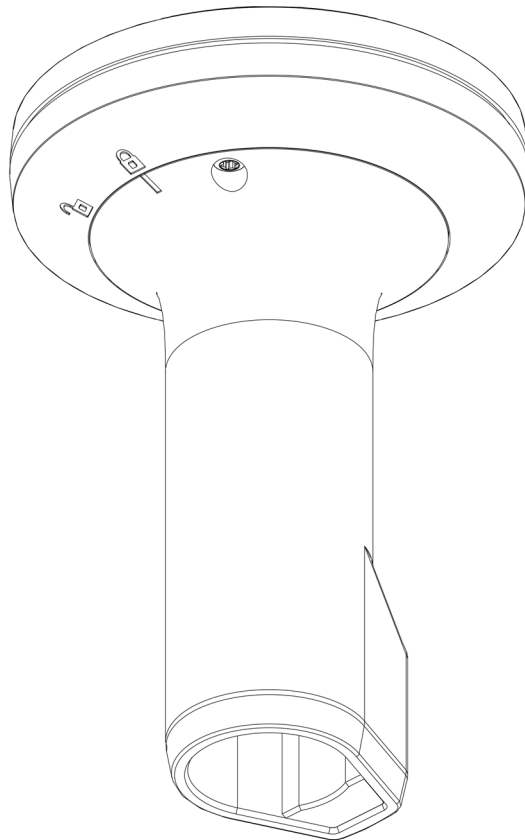

Document Number: 95-100229 REV 1.01

Release date: November 4, 2016

Copyright © Lars Thrane A/S

Denmark

ALL RIGHTS RESERVED

This Document is of © copyright to Lars Thrane A/S. It contains proprietary information, which is disclosed for information purposes only. The contents of this document shall not in whole or in part be used for any other purpose without prior permission from Lars Thrane A/S.

Disclaimer

Any responsibility or liability for loss or damage in connection with the use of this product and the accompanying documentation is disclaimed by Lars Thrane A/S. The information in this manual is provided for information purposes only, is subject to change without notice, and may contain errors or inaccuracies. Manuals issued by Lars Thrane A/S are periodically revised and updated. Anyone relying on this information should acquire the most current version e.g. from Lars Thrane A/S. Lars Thrane A/S is not responsible for the content or accuracy of any translations or reproductions, in whole or in part, of this manual from any other source.

Copyright

© 2016 Lars Thrane A/S. All rights reserved.

Disposal

Old electrical and electronic equipment marked with this symbol can contain substances hazardous to human beings and the environment. Never dispose these items together with unsorted municipal waste (household waste). In order to protect the environment and ensure the correct recycling of old equipment as well as the re-utilization of individual components, use either public collection or private collection by the local distributor of old electrical and electronic equipment marked with this symbol. Contact the local distributor or dealer for information about what type of return system to use.



IMO and SOLAS

The equipment described in this manual is intended for use on leisure and commercial marine boats not covered by the International Maritime Organization (IMO) and Safety of Life at Sea (SOLAS) regulations.



Safety Instructions for Installer & Operator

The following safety instructions must be observed during all phases of operation, installation, service and repair of this equipment. Failure to comply with these precautions or with specific warnings elsewhere in this manual violates safety standards of design, manufacture and intended use of the equipment.

Lars Thrane A/S assumes no liability for the customer's failure to comply with these requirements.

Instructions for the Installer



WARNING - Product installation

To ensure correct performance of this equipment, it is strongly recommended that professionals, with expertise, properly trained, and likewise authorized within the industry is completing the installation.



WARNING – Turn off power switch

Turn off the main power switch before installing the equipment described in this manual. Do not connect or disconnect equipment when the main power switch is on.



WARNING – Use only the supplied cable

Use only the supplied power and communication cable for connecting the equipment.



WARNING – Input Power

The input voltage range is: 9-40 VDC.



WARNING – Power supply protection

Make sure that the power supply is adequately protected by a fuse or an automatic circuit breaker when installing the equipment.



WARNING - Explosive atmosphere

Do not operate the equipment in the presence of flammable gases or fumes. Operation of any electrical equipment in such an environment constitutes a definite hazard.



WARNING - Compass safe distance

The compass safe distance for standard and steering compasses is 0.3 m (1 ft). Observe this distance to prevent interference to a magnetic compass.

Instructions for the Operator



WARNING – Do not disassemble

Do not disassemble or modify this equipment. Fire, electrical shock, or serious injury can result.



WARNING – Keep away from live circuits

Operational personnel must not remove product enclosure. Do not service the equipment, with the communication cable connected. Always disconnect and discharge unit, cable and circuits before touching them.



WARNING - Permanent watch

In case of smoke or water leaks into the equipment, immediately turn off the power. Continued use of the equipment can cause fire or electrical shock. Keep access and permanent watch of the equipment in order to prevent any unwanted escalation.



WARNING - Safe navigation

This product is intended only as an aid to navigation and must never be used in instead of sound navigation judgement.

No one navigation device should ever be solely relied upon for the navigation of a vessel. Always confirm position against all available aids to navigation, for safety of vessel and crew.

If the safety precautions and warnings above are not followed, warranty will be void.

Required information for the reader

Throughout this document, essential information will be presented to the reader. The following text (emphasized) has the following meaning and/or implication:

WARNING: A 'Warning' is an Operation or Service procedure that, if not avoided, may cause a hazard situation, which could result in personnel death or serious injury.

IMPORTANT: Text marked 'Important' provides essential information to the reader, and is key information to the user in order for the equipment to work properly. Damage to the equipment can occur if instructions are not followed.

NOTE: A 'Note' provides essential information to the reader.

About this manual

Intended readers

This is a User & Installation Manual for the LT-300 Global Navigation Satellite System Receiver, LT-300 GNSS Receiver. The manual is primarily intended for installers and service personnel.

Personnel installing or servicing the system should be professionals, with technical expertise, properly trained, and likewise authorized.

All safety instructions and guidelines in this manual must be observed. The safety instructions are listed in the beginning of the manual. The guidelines are to be found in the separate chapters, where it is needed.

Manual overview

This manual has the following chapters:

- **Introduction** – *provides a high-level description of the product, technology, performance, installation options, and installation steps to be completed.*
- **Quick installation guide** – *a short guide providing a minimum of information to complete an installation.*
- **Pre-Installation** – *provides a short description of mounting and installation considerations.*
- **Installation Procedure** – *provides a short description of the installation procedure, which is required to complete.*
- **Mounting** – *mounting of the unit, with a step-by-step instruction for both pole and roof mount installations.*
- **Connecting** – *a description of the unit connector, 8-pin multi cable, connecting to NMEA 0183, connecting to NMEA 2000, connecting to power, and connecting the LT-Service Tool.*
- **Configuration** – *listing of all the relevant setup functions, which needs to be considered during the installation.*
- **LT-Service Tool** – *a short description of the LT-Service Tool. A PC-program, communicating over NMEA 0183, which is supporting configuration and maintenance functions.*
- **Troubleshooting** – *if the unit is not working as expected, please check this guide to help resolve the problem.*
- **Service and repair** – *a short description of what to do in case of a defective unit.*

This manual has the following appendixes:

- Outline Drawings
- Performance
- Specifications
- NMEA 0183 Sentences
- NMEA 2000 PGNs
- LT-Service Tool (commands)
- Declaration of Conformity

Software versions

This manual is applicable to the following software:

Software Versions	
Description	Version
LT-300 GNSS Receiver	1.02
LT-Service Tool	1.05

TABLE 1: SOFTWARE VERSIONS

Record of Revisions

Rev.	Description	Release Date	Initials
1.00	Original document	March 23, 2016	PT
1.01	Document is updated with the following new features: <ul style="list-style-type: none">• Configuration of NMEA 0183 sentences	November 4, 2016	PT

Table of Contents

INTRODUCTION	1
QUICK INSTALLATION GUIDE	3
PRE-INSTALLATION	5
INSTALLATION PROCEDURE	7
MOUNTING	8
CONNECTING	20
CONFIGURATION	26
MMI DESCRIPTION	29
LT-SERVICE TOOL	30
TROUBLESHOOTING	32
SERVICE AND REPAIR	34
APP. A - OUTLINE DRAWINGS	35
APP. B - PERFORMANCE	37
APP. C - SPECIFICATIONS	38
APP. D - NMEA 0183 SENTENCES	39
APP. E - NMEA 2000 PGNS	41
APP. F - LT-SERVICE TOOL (COMMANDS)	42
APP. G - DECLARATION OF CONFORMITY	43

Introduction

Congratulations on your purchase of the LT-300 Global Navigation Satellite System (GNSS) Receiver!

The LT-300 GNSS Receiver is a maritime navigation product from Lars Thrane A/S. The LT-300 GNSS Receiver is designed for the leisure as well as the professional maritime markets. The LT-300 GNSS Receiver meets all standards and certification requirements needed for worldwide maritime navigation equipment.

Performance

The LT-300 GNSS Receiver is capable of providing positions with an accuracy better than 2 meters. The LT-300 GNSS Receiver outputs navigation data (up to 10 Hz): UTC time and date, position, course over ground, speed over ground, GNSS satellite information and magnetic variation, in order to give your vessel smooth navigation capabilities. The 72-channel GNSS receiver benefits from advanced technologies such as:

- Receive and track multiple satellite systems (GPS, QZSS, GLONASS, and BeiDou)
- Support for Satellite-Based Augmentation System (SBAS): EGNOS, WAAS, and MSAS

The LT-300 GNSS Receiver is designed and built for the extremely demanding and rough environment at sea and with an operational temperature range from -40°C to +55°C (-40°F to +131°F).

Installation & Navigation

The LT-300 GNSS Receiver is easy to mount on a 1" pole or roof-mount, with a single cable supporting NMEA 0183, NMEA 2000, and power. The LT-300 GNSS Receiver can be configured to either 4800 or 38400 baud (NMEA 0183), and open or terminated (NMEA 2000). Use the LT-Service Tool for optional configuration of the LT-300 GNSS Receiver. The LT-Service Tool is a PC program, which may run on any Windows PC.

More than 40 years of experience have been put into the design and construction of the advanced LT-300 GNSS Receiver, with an exceptional performance and specification level.

Installation Guide

The following steps, with reference to relevant chapters, will provide you with information, considerations, and guidance on how to complete a successful installation:

- | | | |
|---------|-------------------------------------|--|
| Step 1: | Pre-installation and considerations | see <i>Pre-Installation</i> on page 5. |
| Step 2: | Mounting the unit | see <i>Mounting</i> on page 8. |
| Step 3: | Connecting the unit | see <i>Connecting</i> on page 20. |
| Step 4: | Configuring the unit | see <i>Configuration</i> on page 26. |

NOTE: A quick installation overview is presented in the *Quick Installation Guide* on page 3. Here most of the necessary information is provided to perform a fast installation and take the product in use. It is recommended to use the entire LT-300 User & Installation Manual as guidance for the best possible and complete installation.

NOTE: A more detailed installation procedure is available in *Installation Procedure* on page 7.

Quick Installation Guide

LT-300 Global Navigation Satellite System Receiver

Congratulations on your purchase of the LT-300 Global Navigation Satellite System (GNSS) Receiver!

The LT-300 GNSS Receiver is capable of providing accurate positions better than 2 meters in 95 % of the time. The LT-300 GNSS Receiver outputs navigation data (up to 10 Hz): UTC time and date, position (latitude and longitude), course over ground, speed over ground, GNSS satellite information, and magnetic variation.

NOTE: Refer to the 95-100229 LT-300 User & Installation Manual for detailed information on installation requirements and guidance.

Unpacking

Unpack the LT-300 GNSS Receiver and check that the following items are present:

- LT-300 GNSS Receiver
- LT-300 GNSS Pole & Roof Mount (incl. screws for installation)
- 10m Cable Multi 8-pin Simple-Cut (M)
- Screw-in Conn. NMEA 2000 Micro-C (M)
- Quick Installation Guide
- Safety Instructions Sheet
- Unit Test Sheet



WARNING

Refer to the 95-100229 LT-300 User & Installation Manual for Safety Instructions.

Installation

Mounting

Mounting considerations:

- Mount the unit horizontally
- Mount the unit with free line of sight to GNSS satellites. If the Roof Mount is used for below deck installation, make sure that the unit is capable of receiving signals from the GNSS satellites
- Mount the unit on a rigid structure with a minimum of exposure to vibration and shock
- Mount the unit in an area with an ambient temperature between -40°C and +55°C (-40°F and +131°F)
- The minimum compass safe distance is 0.3 m. (1 ft.)

IMPORTANT: The pinol screw used for fastening the pole mount shall not exceed 0.8 NM (0.6 lbs/ft).

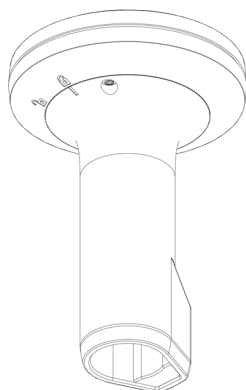

FIGURE 1: LT-300 GNSS RECEIVER WITH POLE MOUNT INSTALLATION

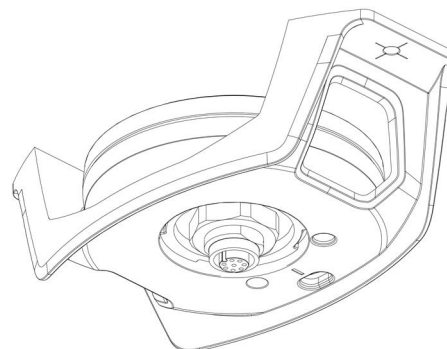

FIGURE 2: LT-300 GNSS RECEIVER WITH ROOF MOUNT INSTALLATION

Connecting

The LT-300 GNSS Receiver connector and cable interconnect details are listed in Table 2 and Figure 3.

LT-300 GNSS Interconnect Details		
Pin No.	Wire Color	Wire Designation
1	Brown	TxD-
2	Yellow	TxD+
3	Black	GND
4	White	CAN_H
5	Blue	CAN_L
6	Orange	RxD+
7	Green	RxD-
8	Red	Vsupply

TABLE 2: LT-300 GNSS RECEIVER MULTI CABLE WIRE COLOR AND DESIGNATION.

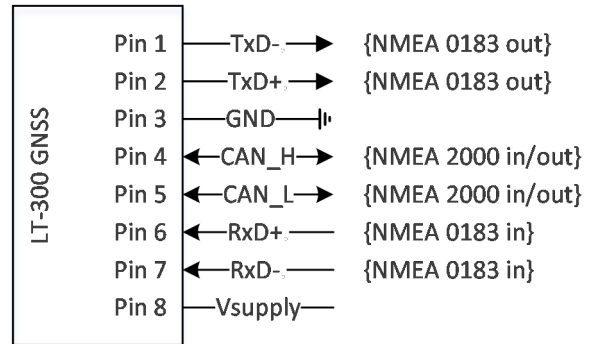

FIGURE 3: TRANSMIT AND RECEIVE DIRECTIONS FOR THE LT-300 GNSS RECEIVER.

NMEA 0183 Baud rate

The NMEA 0183 baud rate is configured by selecting the input level of the NMEA 0183 Rx signals (RxD+/RxD-), see Table 3.

LT-300 GNSS Baud Rate Configuration		
Mode	RxD+/RxD-	Baud Rate
Option 1 (default)	Floating (not connected)	4800
Option 2	Grounded (connected to GND)	38400

TABLE 3: CONFIGURATION OF LT-300 GNSS RECEIVER NMEA 0183 BAUD RATE.

NMEA 2000 ‘Open’ or ‘Terminated’

The LT-300 GNSS Receiver is configured to ‘Open’ (NMEA 2000) from the factory. The LT-Service Tool can be used for configuration of NMEA 2000 ‘Terminated’.

Configuration

Use the LT-Service Tool for optional configuration of the LT-300 GNSS Receiver. The LT-Service Tool is a PC program which may run on any Windows PC. The LT-Service Tool is connected to the LT-300 GNSS Receiver via the NMEA 0183 interface, see Figure 4.

LT-Service Tool Key Features:

- Configuration of GNSS receiver (GPS, SBAS, GLONASS and BeiDou)
- Configuration of NMEA 0183 sentences
- Configuration of NMEA 2000 ‘Open’ or ‘Terminated’
- Status of unit (POST, CM, general status)
- Monitoring of NMEA 0183 sentences
- Live Navigation data
- Generation of a Diagnostic Report
- Upload of new Application Software

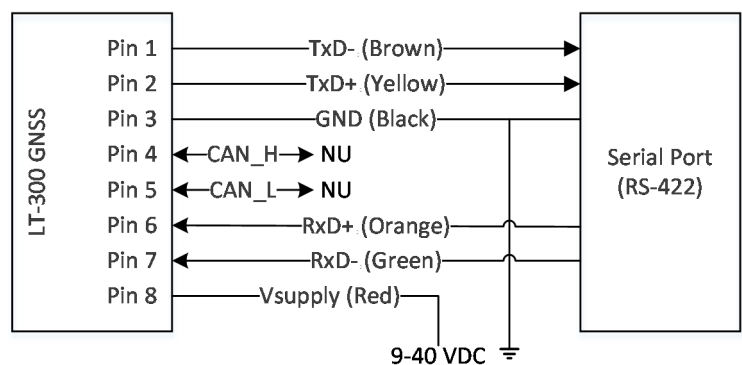

FIGURE 4: WIRING OF THE LT-300 GNSS RECEIVER TO A SERIAL PORT (RS-422).

Pre-Installation

Unpacking (in-the-box)

Unpack your LT-300 GNSS Receiver and check that the following items are present:

- LT-300 GNSS Receiver
- LT-300 GNSS Pole & Roof Mount (incl. screws for installation)
- 10m Cable Multi 8-pin Simple-Cut (M)
- Screw-in Conn. NMEA 2000 Micro-C (M)
- Quick Installation Guide
- Safety Instructions Sheet
- Unit Test Sheet

Inspection

Inspect the shipping cartons and/or wooden box immediately upon receipt for evidence of damage during transport. If the shipping material is severely damaged or water stained, request that the carrier's agent be present when opening the cartons and/or wooden box. Save all box packing material for future use.

After unpacking the system and opening the cartons, inspect it thoroughly for hidden damage and loose components or fittings. If the contents are incomplete, if there is mechanical damage or defect, or if the system does not work properly, notify your dealer.

WARNING: To avoid electric shock, do not apply power to the LT-300 GNSS Receiver if there is any sign of shipping damage to any part of the unit or the outer cover. Read the Safety Instructions at the front of this manual before installing or operating the unit.

Mounting and installation considerations

For optimum system performance, some guidelines on where to install or mount the LT-300 GNSS Receiver must be followed. It is recommended to mount the unit in a location, with as much free line of sight as possible, while making sure that the support structure fulfills the requirements for pole or roof mount installation:

- Mount the unit horizontally
- Mount the unit with unobstructed view to the sky. If the Roof Mount is used for below deck installation, make sure that the unit is capable of receiving signals from the GNSS satellites
- Mount the unit on a rigid structure with a minimum of exposure to vibration and shock
- Mount the unit in an area with an ambient temperature between -40°C and +55°C (-40°F to +131°F)
- Mount the unit at least 1 m. (3 ft.) away from radio transmitting antennas (VHF, UHF, MF-HF, Inmarsat, Iridium, Transmitting VSAT, etc.)
- Mount the unit with a minimum angle of 20 degrees towards a radar antenna (above or below).
- The compass safe distance for standard and steering compasses is 0.3 m (1 ft). Observe this distance to prevent interference to a magnetic compass.

IMPORTANT: The pinol screw used for fastening the pole mount shall not exceed 0.8 NM (0.6 lbf-ft).

Water intrusion

It is recommended not to use pneumatic tools for cleaning the LT-300 GNSS Receiver, especially at a short distance, and directly at the split between the top and bottom part of the enclosure.

Pole or Roof Mount installation

It is possible to use either a pole or roof mount, when installing the LT-300 GNSS Receiver, see Figure 5 (roof mount) and Figure 6 (pole mount).

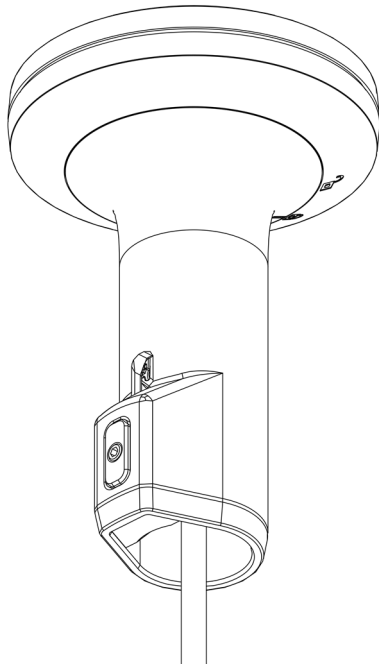

FIGURE 6: LT-300 GNSS RECEIVER WITH POLE MOUNT.

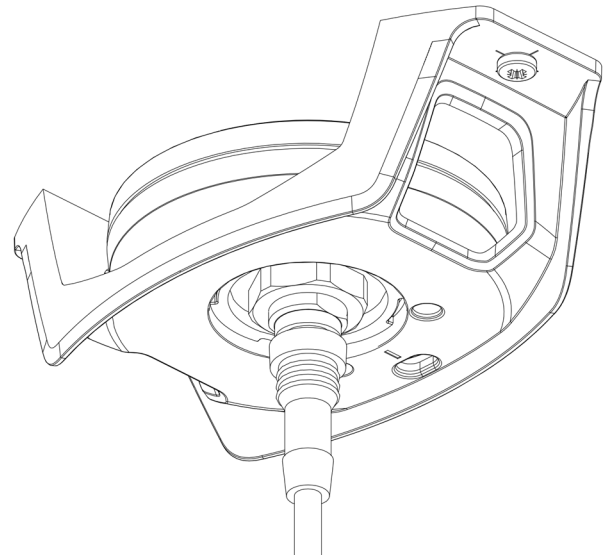

FIGURE 5: LT-300 GNSS RECEIVER WITH ROOF MOUNT.

The following two sub-chapters will in details, step-by-step, describe how to complete an installation with either a pole or roof mount

- Pole mount installation, see *Pole Mount installation* on page 8
- Roof mount installation, see *Roof mount installation* on page 15

NOTE: The LT-300 GNSS Receiver is delivered with both a Pole Mount and a Roof Mount. For further details on what is in-the-box, see *Unpacking* on page 5.

Installation Procedure

The LT-300 GNSS Receiver has to be installed and configured according to the procedure described in this chapter. The LT-300 GNSS Receiver installation procedure is illustrated in Figure 7.

Mounting on page 8

The LT-300 GNSS Receiver can be mounted with a pole or roof mount. Make sure that the unit is capable of receiving signals from the GNSS satellites (see *Mounting and installation considerations* on page 5).

Connecting on page 20

The LT-300 GNSS Receiver is connected to NMEA 0183, NMEA 2000, and power via the proprietary 8-pin multi cable, which is included in the box. This chapter describes how to connect the 8-pin multi cable to NMEA 0183, NMEA 2000, and power.

Configuration on page 26

The LT-300 GNSS Receiver has to be configured with respect to the specific installation requirements. The following configurations shall be considered during installation:

- NMEA 0183 baud rate (grounding RxD+/RxD-)
- NMEA 0183 sentences
- NMEA 2000 termination
- GNSS receiver

Except for the NMEA 0183 baud rate, the above configurations can be configured via the LT-Service Tool. A complete description of the configuration options are available in *Configuration* on page 26.

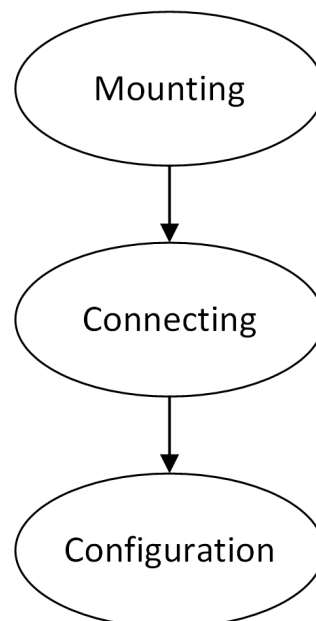

FIGURE 7: LT-300 GNSS INSTALLATION PROCEDURE TO BE COMPLETED FOR OPTIMAL PERFORMANCE.

Mounting

Pole Mount installation

Step 1: Unpack the LT-300 GNSS Receiver and make a record of the unit serial number for support or warranty issues that could occur in the future. The unit serial number label is fixed on the pole mount as illustrated on Figure 8.

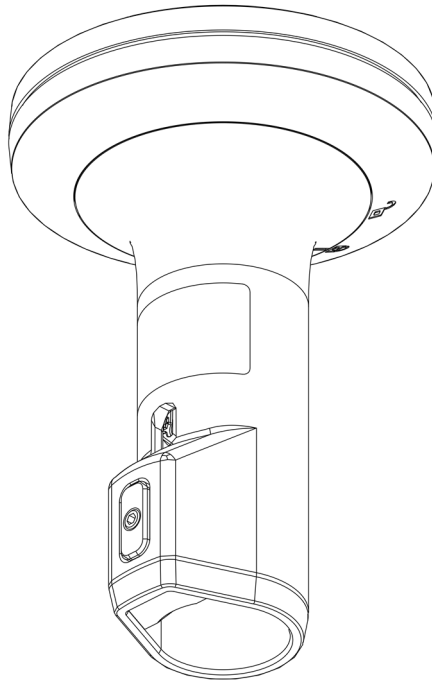

FIGURE 8: POLE MOUNT INSTALLATION STEP 1 (MAKE A RECORD OF THE UNIT SERIAL NUMBER)

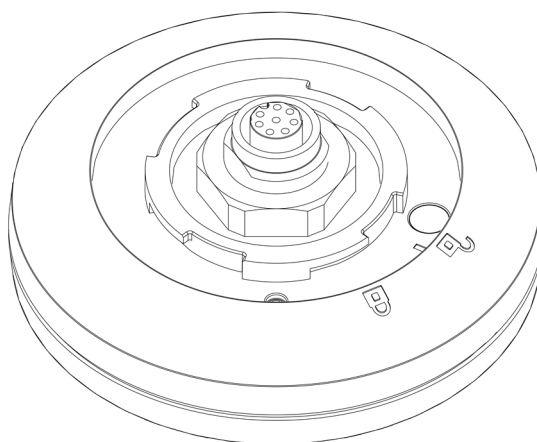

FIGURE 9: POLE MOUNT INSTALLATION STEP 1 (BOTTOM SIDE OF THE LT-300 GNSS RECEIVER)

Step 2: Please refer to *NMEA 0183 Baud rate* on page 26 for details on NMEA 0183 baud rate settings and *LED Color Description* on page 29 for LED description. Figure 10 is illustrating the bottom side of the LT-300 GNSS Receiver; highlighting the 2-color LED, the locking symbols, and the safety lock hole.

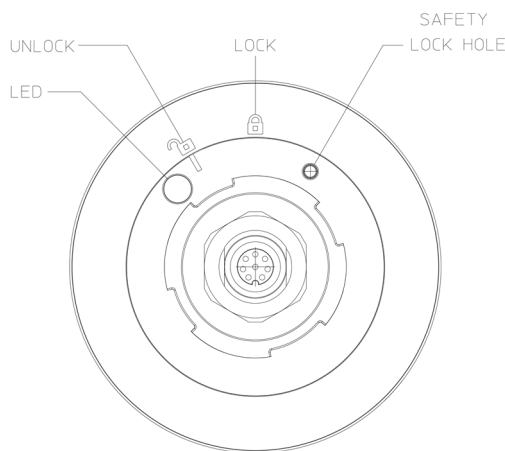

FIGURE 10: POLE MOUNT INSTALLATION STEP 2 (BOTTOM SIDE OF LT-300 GNSS RECEIVER)

Step 3: Locate an appropriate location for the pole mount installation. See drawings under step 3 with respect to pole mount installation.

IMPORTANT: Make sure that the LT-300 GNSS Receiver is capable of receiving signals from the GNSS satellites (see *Mounting and installation considerations* on page 5 for details) and no compass within 0.3 m. (1 ft.) of the unit. Mount the LT-300 GNSS Receiver at least 1 m. away from VHF, UHF, MF-HF, Inmarsat, Iridium, etc. radio transmitting equipment. Make sure that the LT-300 GNSS Receiver minimum has a 20-degree angle towards a radar antenna (above or below).

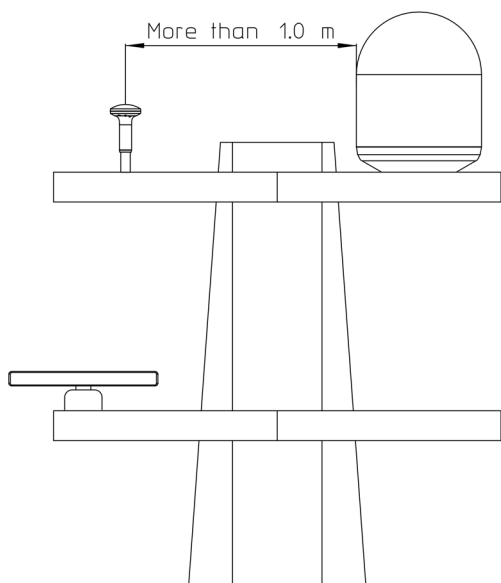

FIGURE 12: POLE MOUNT INSTALLATION STEP 3 (LOCATE AN APPROPRIATE LOCATION)

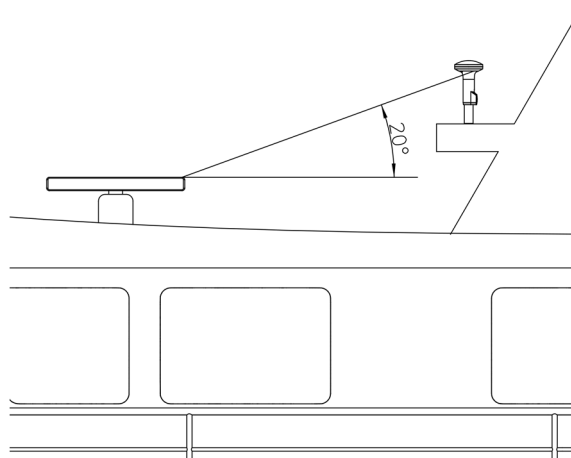

FIGURE 11: POLE MOUNT INSTALLATION STEP 3 (LOCATE AN APPROPRIATE LOCATION)

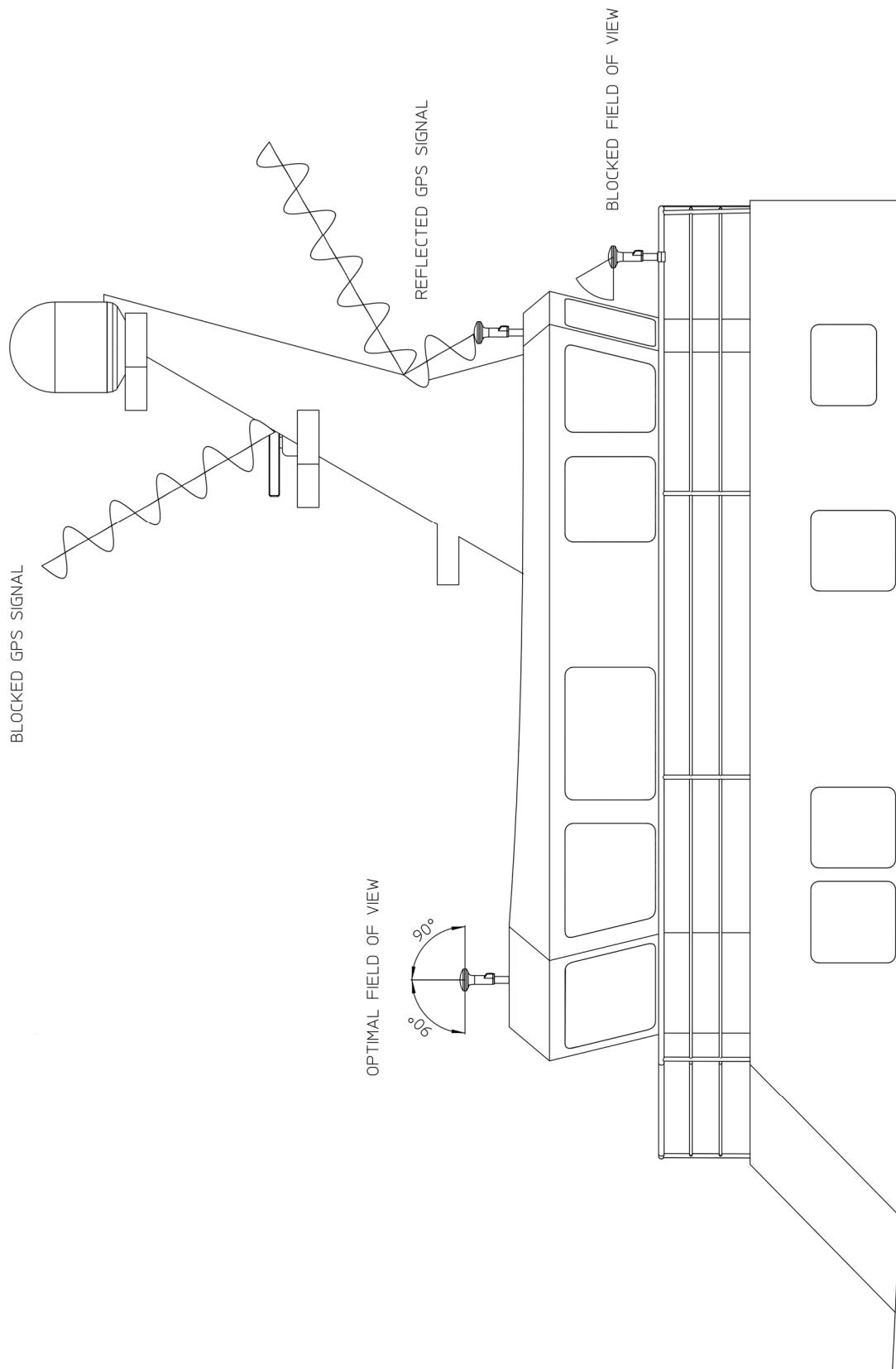

FIGURE 13: POLE MOUNT INSTALLATION STEP 3 (LOCATE AN APPROPRIATE LOCATION)

Step 4: Complete the internal or external cable routing. Feed the communication cable through the pole mount.

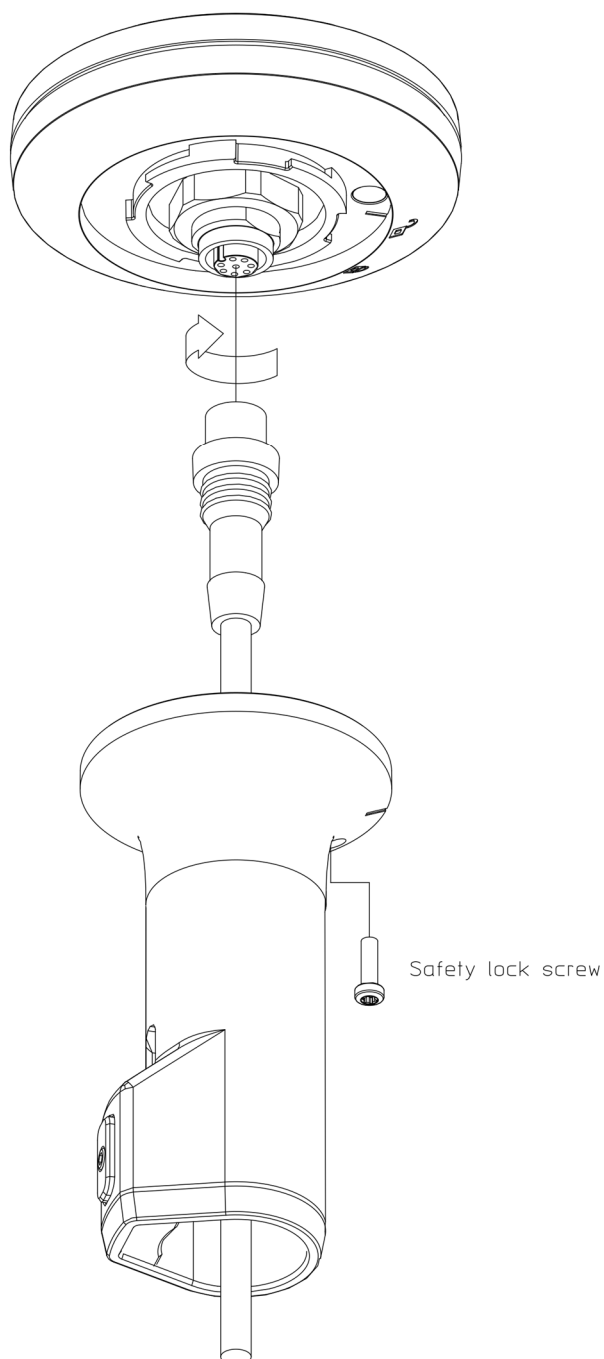

FIGURE 14: POLE MOUNT INSTALLATION STEP 4 (INTERNAL ROUTING OF THE COMMUNICATION CABLE)

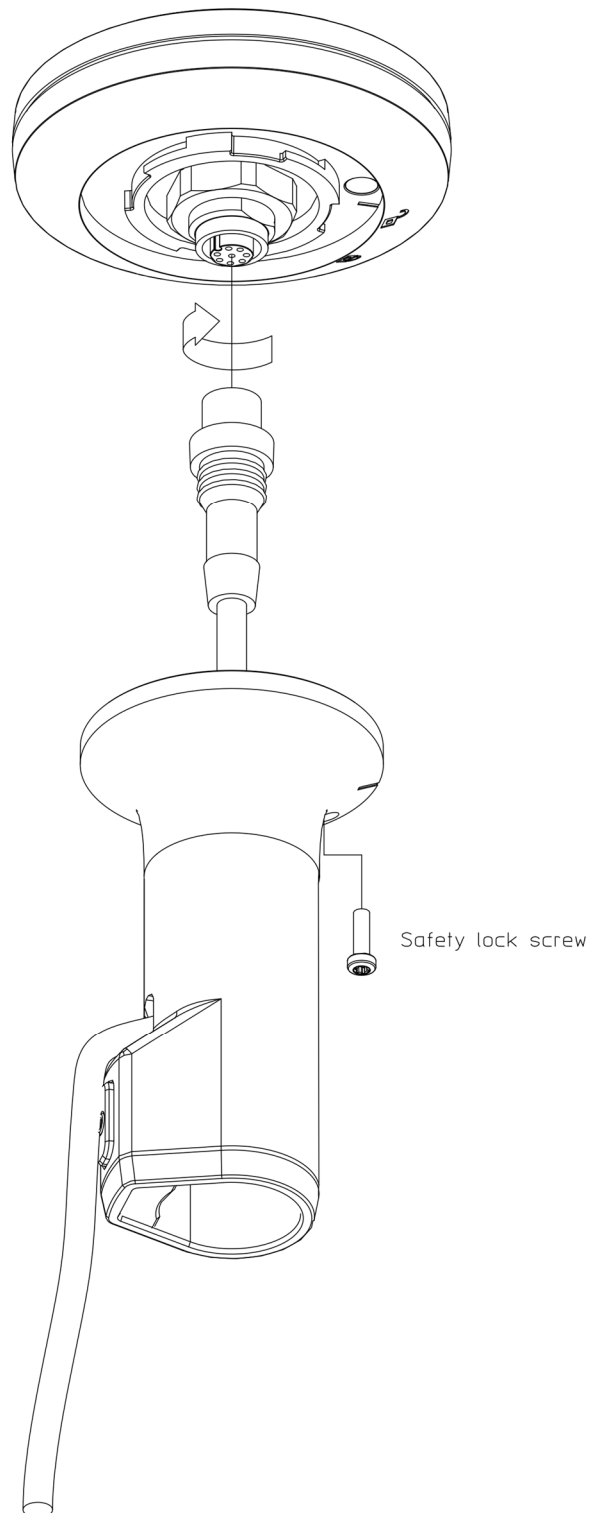

FIGURE 15: POLE MOUNT INSTALLATION STEP 4 (EXTERNAL ROUTING OF THE COMMUNICATION CABLE)

Step 5: Fasten the pole mount by securing the two screws as illustrated in Figure 16 (pinol and safety lock screw).

IMPORTANT: The pinol screw used for fastening the pole mount to the 1" tube shall not exceed 0.8 NM (0.60 lbs/ft). The Safety lock screw used for fastening the pole mount to the LT-300 GNSS Receiver shall not exceed 0.6 NM (0.44 lbs/ft).

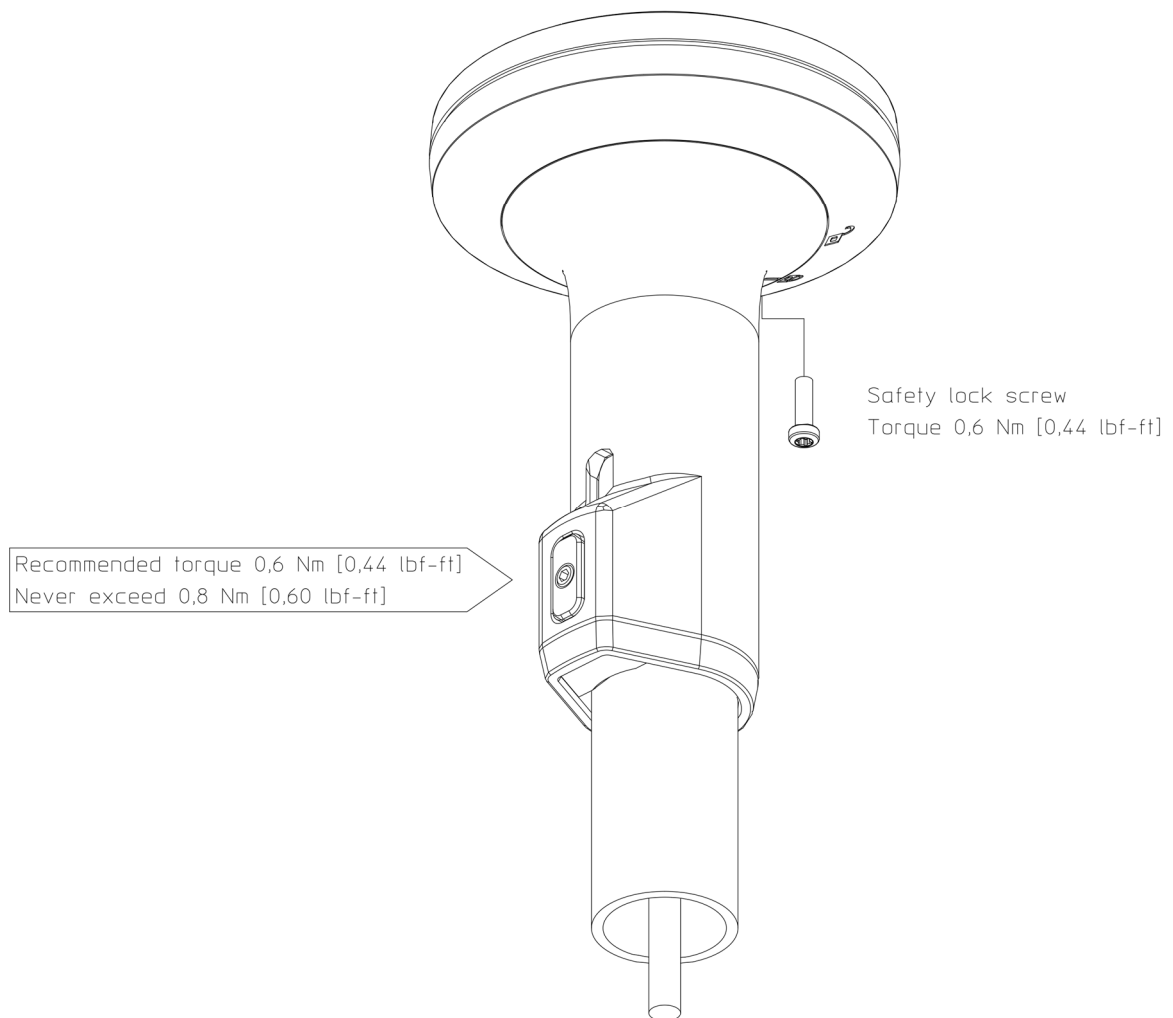

FIGURE 16: POLE MOUNT INSTALLATION STEP 5 (SECURING SCREWS)

Step 6: The mounting is now completed. Install the simple-cut end of the communication cable according to the details provided in *Connecting* on page 20.

NOTE: GNSS satellite configuration can be performed using the LT-service tool, see *GNSS Receiver* on page 27.

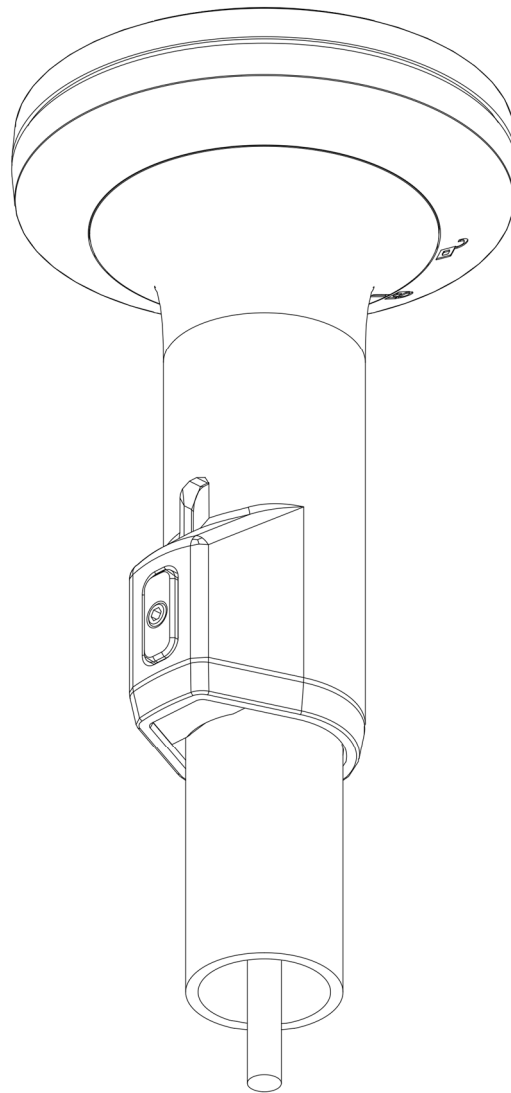

FIGURE 17: POLE MOUNT INSTALLATION STEP 6 (INSTALL THE SIMPLE-CUT END OF THE COMMUNICATION CABLE)

Roof mount installation

Step 1: Locate an appropriate location for the roof mount installation.

IMPORTANT: Make sure that nothing is blocking the GNSS satellite signals (see *Mounting and installation considerations* on page 5 for details) and that no compass is within 0.3 m. / 1 ft. of the LT-300 GNSS Receiver.

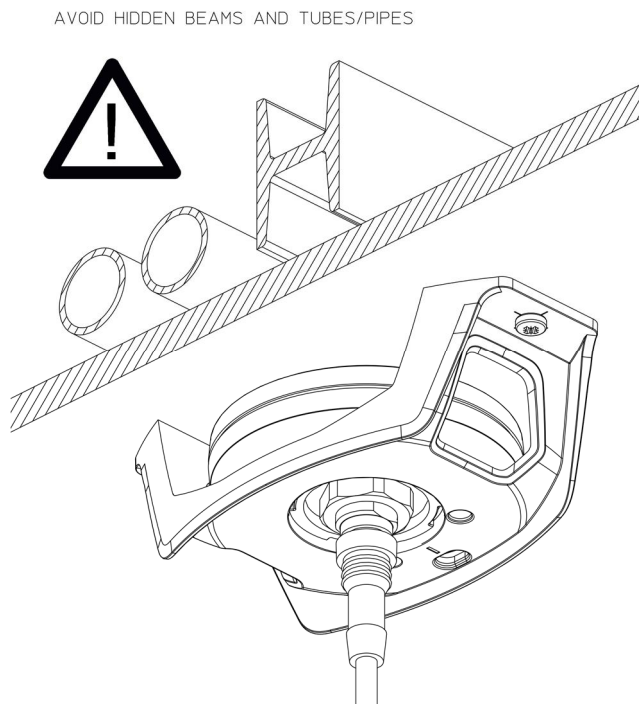

FIGURE 18: ROOF MOUNT INSTALLATION STEP 1 (LOCATE AN APPROPRIATE LOCATION)

Step 2: Measure and mark the installation holes in accordance with the drawing showed in Figure 19. Use the enclosed two stainless A4 screws for mounting.

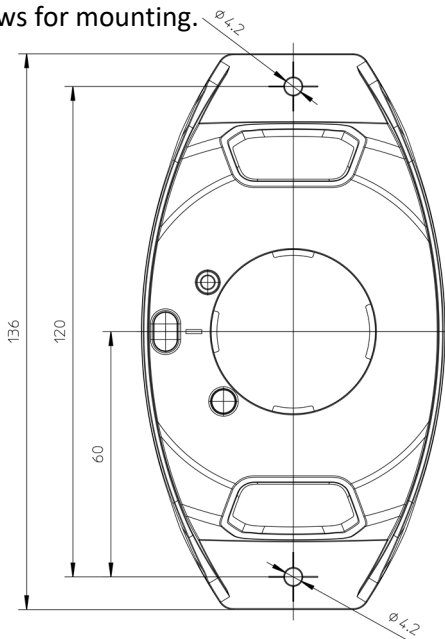

FIGURE 19: ROOF MOUNT INSTALLATION STEP 2 (MEASURE AND MARK THE INSTALLATION HOLES)

Step 3: Unpack the LT-300 GNSS Receiver and make a record of the unit serial number for support or warranty issues that could occur in the future. The unit serial number label is fixed on the pole mount as illustrated in Figure 20.

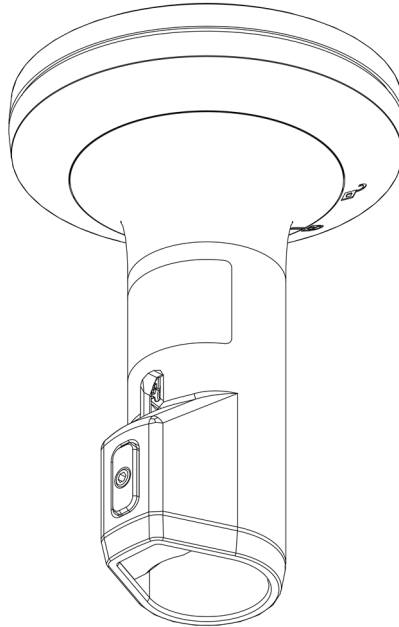

FIGURE 20: POLE MOUNT INSTALLATION STEP 3 (MAKE A RECORD OF THE UNIT SERIAL NUMBER)

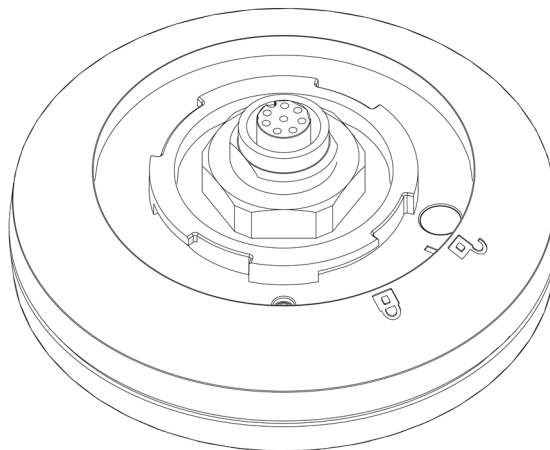

FIGURE 21: ROOF MOUNT INSTALLATION STEP 3 (BOTTOM SIDE OF THE LT-300 GNSS RECEIVER)

Step 4: Please refer to *NMEA 0183 Baud rate* on page 26 for details on NMEA 0183 baud rate settings and *LED Color Description* on page 29 for LED color description. Figure 22 is illustrating the bottom side of the LT-300 GNSS Receiver; highlighting the 2-color LED, the locking symbols, and the safety lock hole.

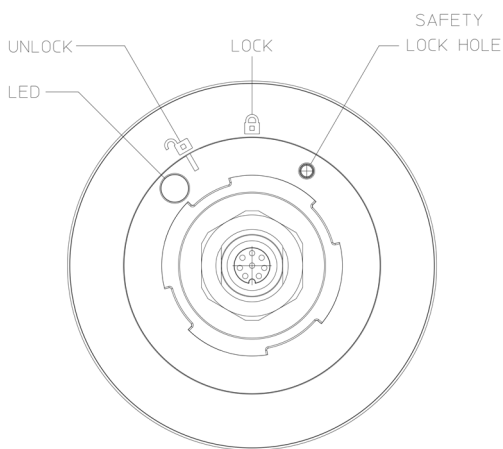

FIGURE 22: ROOF MOUNT INSTALLATION STEP 4 (BOTTOM SIDE OF THE LT-300 GNSS RECEIVER)

Step 5: Fasten the LT-300 GNSS Receiver to the Roof Mount as illustrated in Figure 23 to Figure 26.

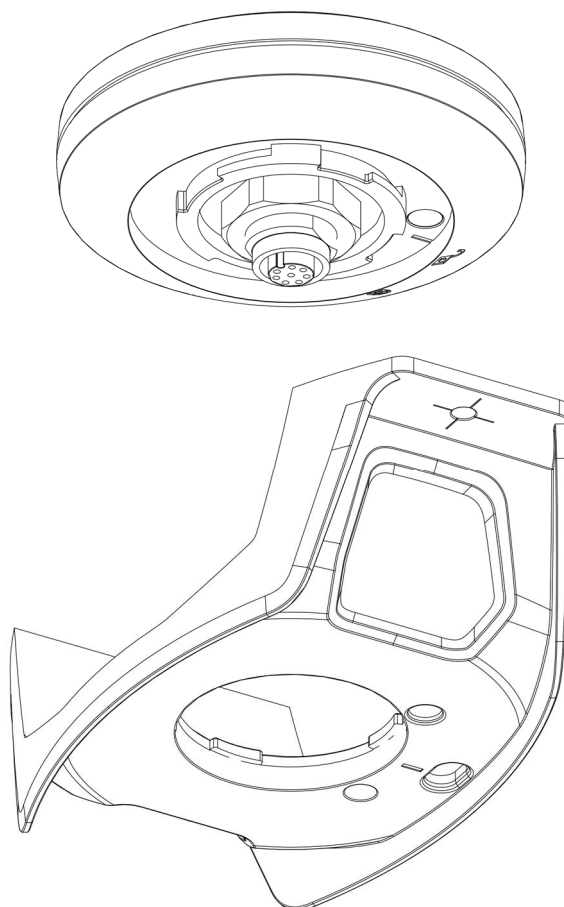
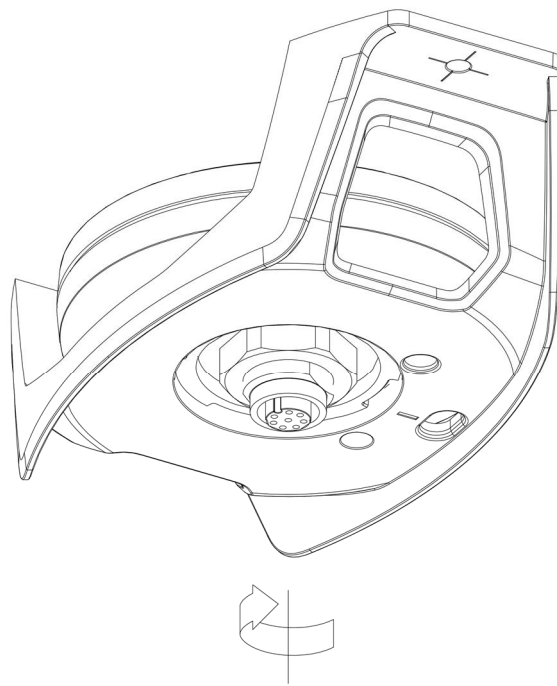

FIGURE 23: ROOF MOUNT INSTALLATION STEP 5 (FASTEN THE LT-300 GNSS RECEIVER TO THE ROOF MOUNT)



To Lock - turn 30° clockwise

FIGURE 24: ROOF MOUNT INSTALLATION STEP 5 (FASTEN THE LT-300 GNSS RECEIVER TO THE ROOF MOUNT)

To Lock - turn LT-300 GNSS 30° clockwise

Lock position - mount safety screw PT 30x10 WN 5452

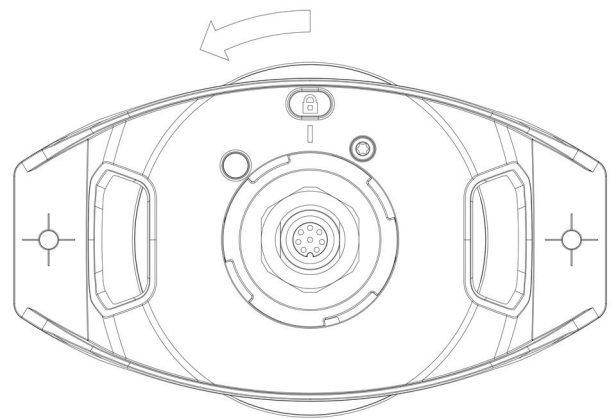
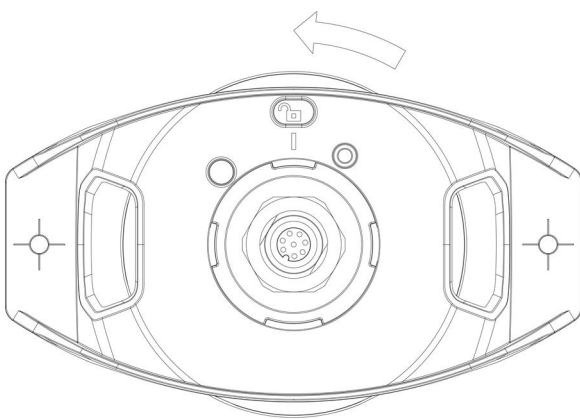

FIGURE 26: ROOF MOUNT INSTALLATION STEP 5 (UNLOCK POSITION OF THE LT-300 GNSS RECEIVER)

FIGURE 25: ROOF MOUNT INSTALLATION STEP 5 (LOCKED POSITION OF THE LT-300 GNSS RECEIVER)

Step 6: Use the two self-cutting stainless screws to mount the Roof Mount against the roof. Secure the LT-300 GNSS Receiver and Roof Mount with the safety lock screw as illustrated in Figure 27. Connect the communication cable.

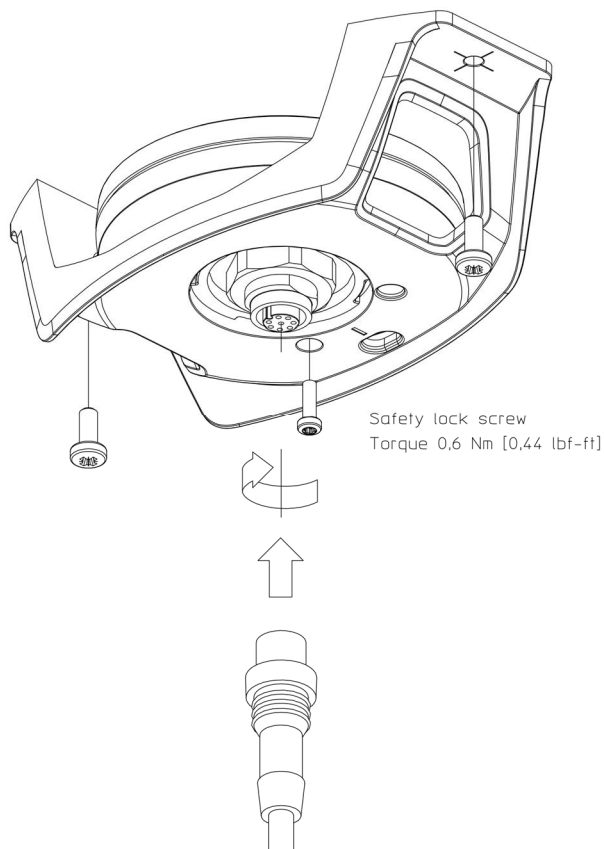

FIGURE 27: ROOF MOUNT INSTALLATION STEP 6 (FASTEN SCREWS AND CONNECT THE COMMUNICATION CABLE)

Step 7: The mounting is now completed. Install the simple-cut end of the communication cable according to the details provided in *Connecting* on page 20.

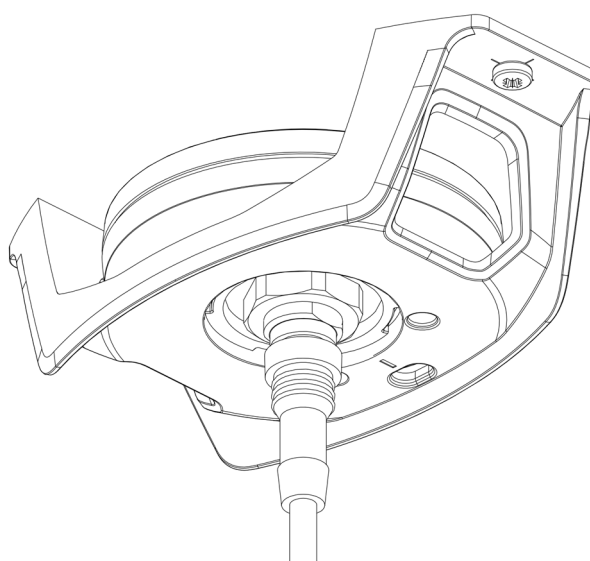

FIGURE 28: ROOF MOUNT INSTALLATION STEP 7 (INSTALL THE SIMPLE-CUT END OF THE COMMUNICATION CABLE)

Connecting

This section provides relevant information for connecting the LT-300 GNSS Receiver to NMEA 0183, NMEA 2000, power, and the LT-Service Tool.

Connector and cable definition

The LT-300 GNSS Receiver has an 8-pin female connector, which is supporting simultaneously data on NMEA 0183 and NMEA 2000. The placement of the LT-300 GNSS connector is illustrated in Figure 29. A detailed connector pin out with pin numbering is illustrated in Figure 30.

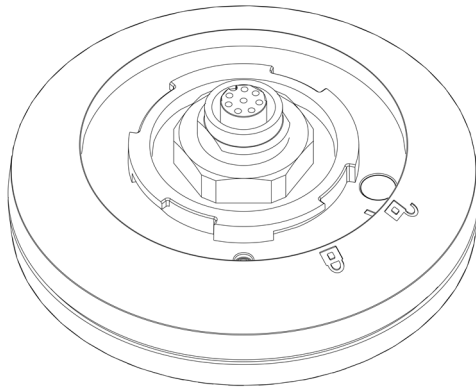

FIGURE 29: LT-300 GNSS RECEIVER (BOTTOM VIEW). 8-PIN FEMALE CONNECTOR USED FOR CONNECTING THE LT-300 GNSS RECEIVER TO NMEA 0183, NMEA 2000, AND POWER.

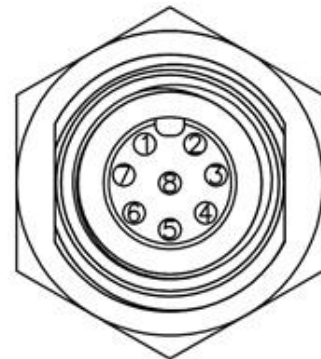

FIGURE 30: LT-300 GNSS CONNECTOR PIN NUMBERING

The LT-300 GNSS connector has a proprietary pin out and therefore a communication cable is always included in-the-box, see *Unpacking (in-the-box)* on page 5. The communication cable is available in two lengths: 10 or 30 meters. The LT-300 GNSS Receiver is delivered including a 10 meter cable (simple-cut). The communication cable, wire color and designation, is illustrated in Table 4.

LT-300 GNSS Interconnect Details		
Pin No.	Wire Color	Wire Designation
1	Brown	TxD-
2	Yellow	TxD+
3	Black	GND
4	White	CAN_H
5	Blue	CAN_L
6	Orange	RxD+
7	Green	RxD-
8	Red	Vsupply

TABLE 4: LT-300 GNSS RECEIVER MULTI CABLE WIRE COLOR AND DESIGNATION.

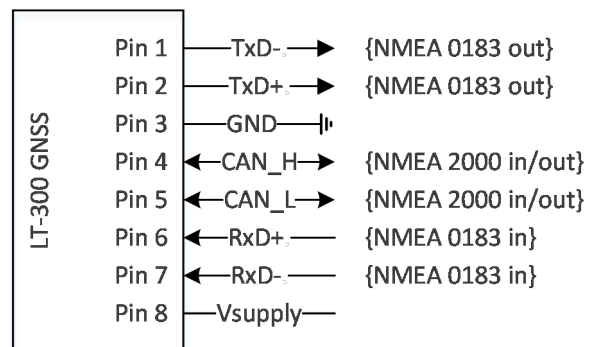

FIGURE 31: TRANSMIT AND RECEIVE DIRECTIONS FOR THE LT-300 GNSS RECEIVER.

NOTE: To avoid any misinterpretation, the transmit (Tx) and receive (Rx) directions are illustrated in Figure 31, relative to the LT-300 GNSS Receiver.

Connecting to NMEA 0183

If connecting the LT-300 GNSS Receiver to a NMEA 0183 device, it is only required to connect the transmit part of the NMEA 0183 wires TxD- (Brown) and TxD+ (Yellow) from the communication cable.

NOTE: Make sure that the LT-300 GNSS Receiver is configured for the desired baud rate (4800 or 38400 baud), see *NMEA 0183 Baud rate* on page 26. Check that both the NMEA 0183 receive device and the LT-300 GNSS Receiver have the same GND reference, as illustrated in Figure 32 and Figure 33.

IMPORTANT: It is recommended to connect the LT-300 GNSS Receiver with a balanced NMEA 0183 connection (RS-422) as illustrated in Figure 32. An unbalanced connection (RS-232), as illustrated in Figure 33, is less robust and should only be considered when using a short communication cable.

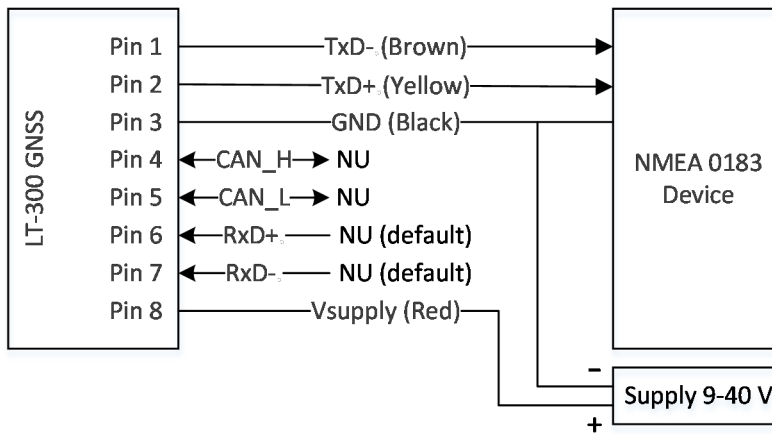

FIGURE 32: CONNECTING THE LT-300 GNSS RECEIVER TO A BALANCED NMEA 0183 DEVICE.

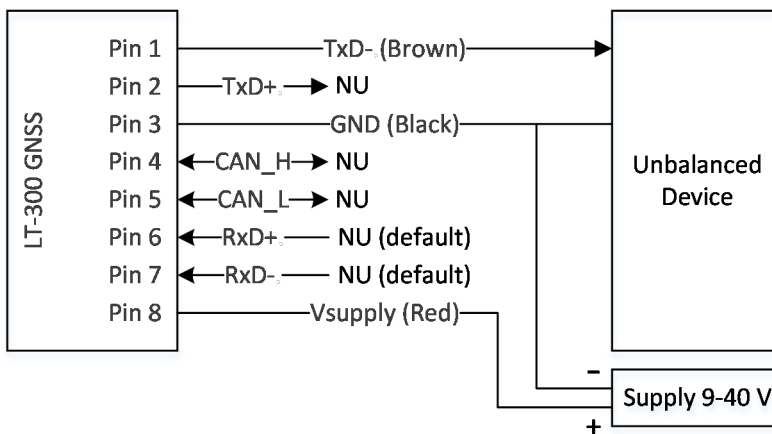

FIGURE 33: CONNECTING THE LT-300 GNSS RECEIVER TO AN UNBALANCED DEVICE.

Connecting to NMEA 2000

If connecting the LT-300 GNSS Receiver to a NMEA 2000 network (drop or backbone) then it is required to use a screw-in connector as illustrated in Figure 34. The screw-in connector is in-the-box together with the LT-300 GNSS Receiver.

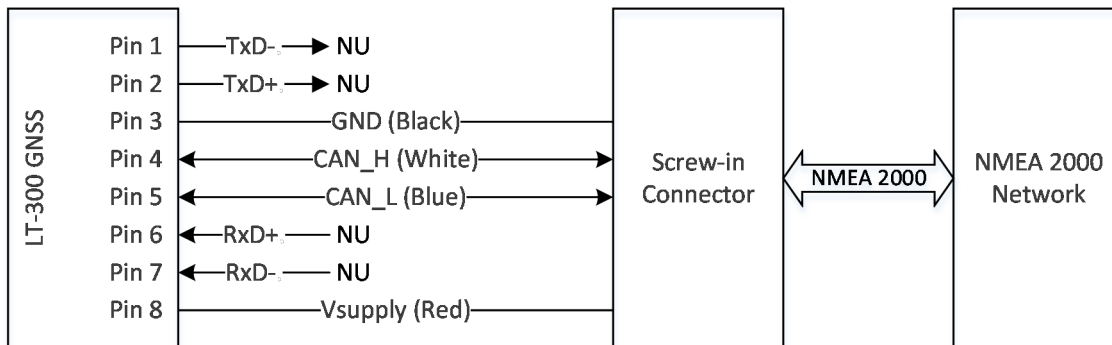

FIGURE 34: CONNECTING THE LT-300 GNSS RECEIVER TO A NMEA 2000 BACKBONE. A SCREW-IN CONNECTOR IS REQUIRED FOR CONNECTING THE LT-300 GNSS RECEIVER TO A NMEA 2000 NETWORK.

NOTE: The screw-in connector is connected to the communication cable by cutting the cable in the right length, stripping the wires, screwing the specific wires to the connector, and then re-assemble the connector again.

The screw-in connector outline is illustrated in Figure 35. The pin-out and numbering of the screw-in connector is illustrated in Figure 36, while the wiring details for interconnection with the communication cable is shown in Table 5.

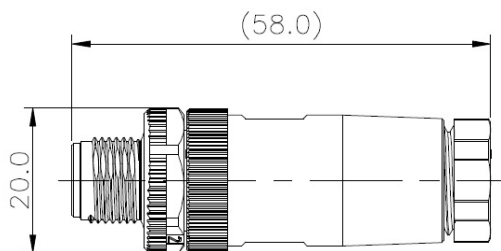

FIGURE 35: NMEA 2000 SCREW-IN CONNECTOR (M) OUTLINE

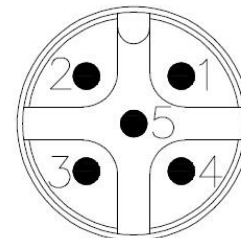

FIGURE 36: NMEA 2000 SCREW-IN CONNECTOR PIN NO.

NMEA 2000 Screw-in Conn. Wiring		
Cable Wire Color	Cable Wire Designation	Screw-in Conn. Pin No.
-	-	1
Red	Vsupply	2
Black	GND	3
White	CAN_H	4
Blue	CAN_L	5

TABLE 5: ILLUSTRATES HOW THE LT-300 GNSS 8-PIN MULTI CABLE IS CONNECTED TO A NMEA 2000 SCREW-IN CONNECTOR.

NOTE: The LT-300 does not require a connection on Pin No. 1: drain/shield. The unit is designed to work with open cable shield.

NOTE: The LT-300 GNSS Receiver can be configured to NMEA 2000 ‘Open’ or ‘Terminated’. The LT-Service Tool must be used to change this configuration (factory default is ‘Open’). The LT-Service Tool is described in *LT-Service Tool* on page 30.

The remaining figures in this sub-chapter does not show the screw-in connector for simplicity.

NMEA 2000 Installation

The LT-300 GNSS Receiver is delivered with a NMEA 2000 screw-in connector, which is used to interconnect the communication cable to a NMEA 2000 backbone. The LT-Service Tool can be used to configure the LT-300 GNSS Receiver to either 'Open' or 'Terminated', see *NMEA 2000 Termination on page 27* (factory default: 'Open'). Figure 37 and Figure 38 are illustrating two options for connecting the LT-300 GNSS Receiver to a NMEA 2000 network (backbone).

NMEA 2000 ('Open')

If the LT-300 GNSS Receiver is installed as illustrated in Figure 37, no internal LT-300 NMEA 2000 bus termination is required (default: 'Open'). The LT-300 GNSS Receiver is connected to the NMEA 2000 backbone using a drop-cable.

IMPORTANT: Make sure that the communication cable, delivered together with the LT-300 GNSS Receiver, is shortened to a maximum length of 6 meters as defined in the NMEA 2000 standard for a drop cable.

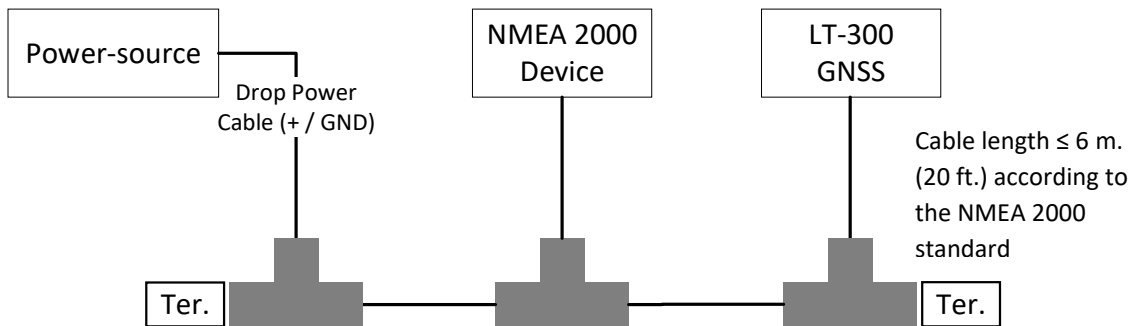

FIGURE 37: LT-300 GNSS RECEIVER CONNECTED TO A NMEA 2000 BACKBONE CONFIGURED TO 'OPEN' (DEFAULT CONFIGURATION). THE NMEA 2000 SCREW-IN CONNECTOR IS NOT ILLUSTRATED IN THIS FIGURE.

NMEA 2000 ('Terminated')

If the LT-300 GNSS Receiver is installed as illustrated in Figure 38, internal LT-300 NMEA 2000 bus termination is required and configuration must be changed from 'Open' to 'Terminated' (default: 'Open'). The LT-Service Tool must be used to make this configuration, see *NMEA 2000 Termination on page 27*. The LT-300 GNSS Receiver is connected to the NMEA 2000 backbone using a standard backbone cable.

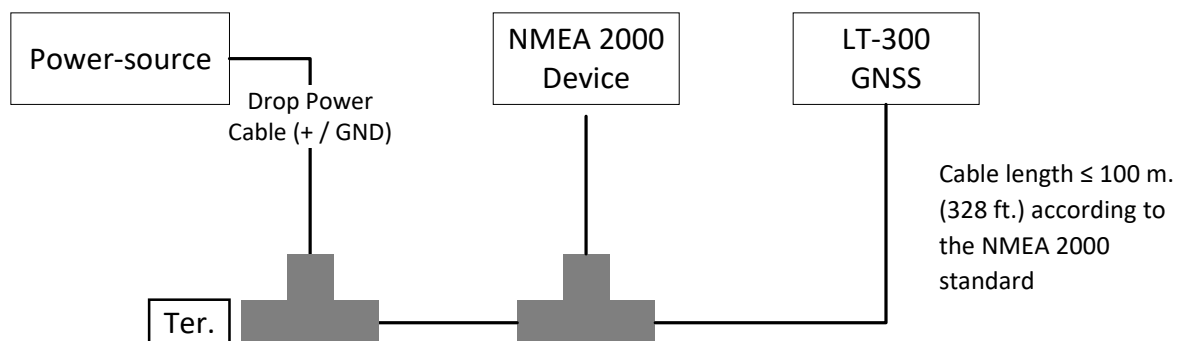

FIGURE 38: LT-300 GNSS RECEIVER CONNECTED TO A NMEA 2000 BACKBONE WITH NMEA 2000 BUS TERMINATION CONFIGURED TO 'TERMINATED'. THE NMEA 2000 SCREW-IN CONNECTOR IS NOT ILLUSTRATED IN THIS FIGURE.

For details on how to connect the communication cable with the NMEA 2000 screw-in connector, see *Connecting to NMEA 2000 on page 22*.

Connecting LT-Service Tool

The LT-Service Tool is a PC program made for configuration, maintenance, and service of the LT-300 GNSS Receiver. Use of the LT-Service Tool is optional. For details and functionality, see *Configuration on page 26* and *LT-Service Tool on page 30*. This sub-chapter is describing how to physically interconnect a PC (with the LT-Service Tool), to a LT-300 GNSS Receiver. The LT-Service Tool is using the NMEA 0183 interface for communicating with the LT-300 GNSS Receiver (both Tx and Rx directions).

Use either a ‘USB to RS-422 converter’ or connect a serial port directly to the LT-300 GNSS Receiver as described in the following sub-sections. The LT-300 GNSS Receiver requires an input voltage of 9-40 VDC. Most of the USB to RS-422 converter’s and serial interfaces are only providing 5 VDC. Make sure that GND on both devices (PC and LT-300 GNSS Receiver) are connected to the same reference.

NOTE: The LT-Service Tool will automatically detect all LT-Navigation devices, which are connected to the PC’s peripheral interfaces (USB and serial). Make sure that Tx and Rx wires are connected correctly. The LT-Service Tool will automatically try both 4800 and 38400 baud to search for possible LT-Navigation devices. If the LT-Service Tool does not automatically detect a LT-Navigation device, check automatically and manual connection modes, described in *LT-Service Tool on page 30*.

USB to RS-422 converter

A standard USB to RS-422 converter, as illustrated in Figure 39, is perfect for providing a communication link in between the LT-Service Tool and the LT-300 GNSS Receiver. The PC is connected to the ‘USB to RS-422 converter’ through a standard USB cable.

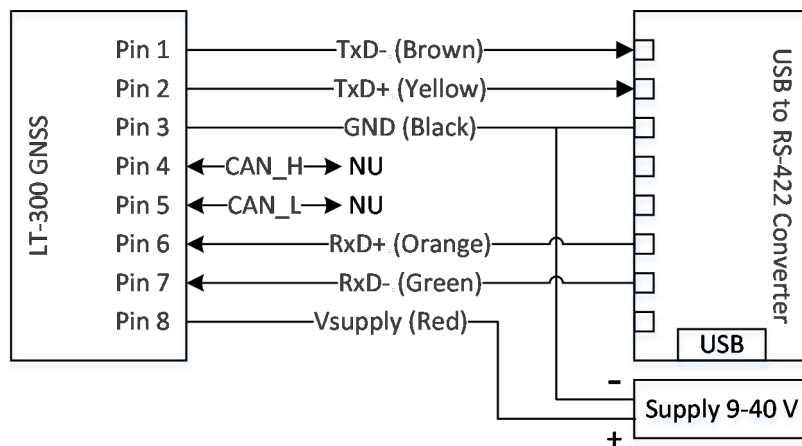

FIGURE 39: USB TO RS-422 CONVERTER PROVIDING THE COMMUNICATION LINK IN BETWEEN THE PC (LT-SERVICE TOOL) AND THE LT-300 GNSS RECEIVER.

NOTE: Windows may wrongfully recognize an USB to Serial device, as a mouse, if the device is transmitting when being plugged into the PC. Avoid this by giving Windows time to recognize the USB to Serial device before powering on the LT-300 GNSS Receiver.

Serial Port (RS-422)

Illustration of a RS-422 interface in between a serial port and the LT-300 GNSS Receiver for providing a communication link for the LT-Service Tool, see Figure 40. The RS-422 interface is balanced and more robust than an unbalanced serial interface, which is illustrated in Figure 41.

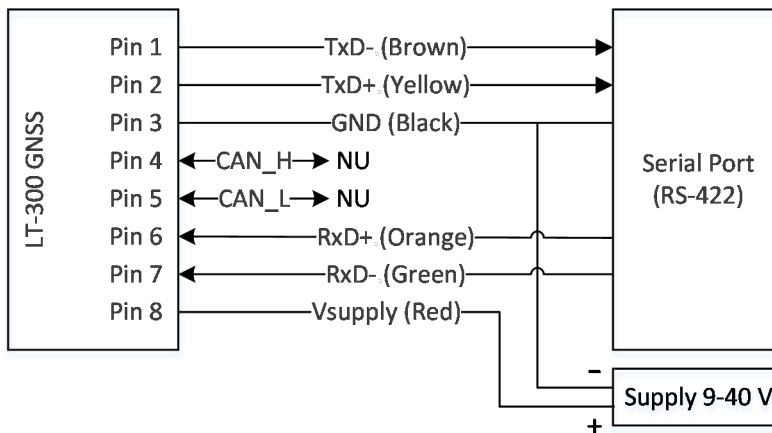

FIGURE 40: RS-422 (BALANCED) SERIAL INTERFACE PROVIDING THE COMMUNICATION LINK IN BETWEEN THE LT-SERVICE TOOL AND THE LT-300 GNSS RECEIVER.

NOTE: The RS-422 interface is using both Tx and Rx transmission lines (balanced/differential) and is therefore a more robust communication link than the RS-232 interface. The LT-300 GNSS Receiver is supporting both RS-422 and RS-232 communicating link to the LT-Service Tool.

Serial port (RS-232)

Illustration of a RS-232 interface in between a serial port and the LT-300 GNSS Receiver for providing a communication link for the LT-Service Tool, see Figure 41.

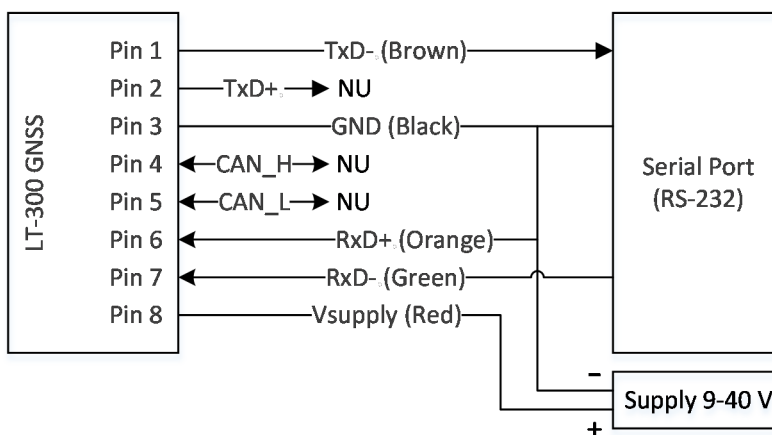

FIGURE 41: RS-232 (UNBALANCED) SERIAL INTERFACE PROVIDING THE COMMUNICATION LINK IN BETWEEN THE LT-SERVICE TOOL AND THE LT-300 GNSS RECEIVER.

NOTE: When using the RS-232 (unbalanced) serial communication link, it is important that the RxD- signal level from the serial port is > 5 VDC for proper operation.

Configuration

This chapter describes how to configure the LT-300 GNSS Receiver. The LT-300 GNSS Receiver can be configured via the LT-Service Tool (see *LT-Service Tool* on page 30).

The following configurations are described in this chapter:

- NMEA 0183 baud rate (grounding RxD-/RxD+)
- NMEA 0183 sentences
- NMEA 2000 termination
- GNSS receiver
- Factory default

NMEA 0183 Baud rate

The NMEA 0183 baud rate is configured by selecting the input level of the NMEA 0183 Rx signals (RxD+/RxD-), see Table 6.

LT-300 GNSS Baud Rate Configuration		
Mode	RxD+/RxD-	Baud Rate
Option 1 (default)	Floating (not connected)	4800
Option 2	Grounded (connected to GND)	38400

TABLE 6: CONFIGURATION OF LT-300 GNSS RECEIVER NMEA 0183 BAUD RATE.

IMPORTANT: It is important that both RxD+ and RxD- have the same input level (floating or grounded). For LT-300 interconnect details (wire colors), see Table 4 on page 20.

NMEA 0183 Sentences

From factory, the LT-300 GNSS Receiver has a default NMEA 0183 sentence configuration that determines which sentences are output at a given baud rate (4800 and 38400). Using the LT-Service Tool, sentences can be enabled/disabled and talker ID changed. Configuration of talker ID, see *GNSS Receiver* on page 27.

NMEA 0183 Sentences			
Configuration	Options	Default	Comments
NMEA 0183	Enable or disable	See comments	See <i>App. D - NMEA 0183 Sentences</i>

TABLE 7: LT-300 GNSS RECEIVER NMEA 0183 SENTENCES.

The default configuration of the NMEA 0183 sentences for respectively 4800 and 38400 baud is illustrated in *App. D - NMEA 0183 Sentences* on page 39.

NOTE: If changing the NMEA 0183 baud rate, the NMEA 0183 sentences configuration will be reset to factory default.

The LT-Service Tool is providing support and guidance when configuring the NMEA 0183 sentences. The LT-Service Tool is providing some functions to verify the correct configuration of the NMEA 0183 sentences:

- stat -> analyzing function showing statistics, hereunder utilization of bandwidth
- mon -> dumping the NMEA 0183 data, to visualize data stream

Example on the LT-Service Tool NMEA 0183 sentences configuration (syntax):

```
lt>nmea0183 sentences RMC:1000 VTG:1000 GGA:1000
```

NOTE: The talker ID shall not be included when configuring the NMEA 0183 sentences. Only 1000 ms (1 Hz) output rate is an option for the NMEA 0183 sentences configuration and shall be included in the syntax, as for the example above.

NMEA 2000 Termination

The LT-300 GNSS Receiver is configured to ‘Open’ (NMEA 2000) from the factory. The LT-Service Tool can be used for setting NMEA 2000 bus termination for the LT-300 GNSS Receiver.

NMEA 2000 Termination			
Configuration	Options	Default	Comments
NMEA 2000	Open or Terminated	Open	lt>nmea2000 bus [open term]

TABLE 8: LT-300 GNSS RECEIVER NMEA 2000 TERMINATION.

IMPORTANT: Use the LT-Service Tool to configure the NMEA 2000 bus termination (‘open’ or ‘terminated’). For further information on the LT-Service Tool, see *LT-Service Tool* on page 30. The NMEA 2000 bus installation is described in *NMEA 2000 Installation* on page 23.

GNSS Receiver

The LT-300 GNSS Receiver is by default configured to the following GNSS satellite reception:

GPS, SBAS, and GLONASS

For a complete list of possible configurations, see Table 9, which may be configured using the LT-Service Tool. For further information on the LT-Service Tool, see *LT-Service Tool* on page 30.

GNSS Satellite Receiver Configuration	
Configuration	GNSS Satellites
Default	GPS, SBAS, GLONASS
Option 1	GPS, SBAS, BeiDou
Option 2	GPS, SBAS
Option 3	GPS
Option 4	GLONASS
Option 5	BeiDou

TABLE 9: GNSS SATELLITE RECEIVER CONFIGURATION

Example on the LT-Service Tool NMEA 0183 sentences configuration (syntax):

```
lt>gnss receiver GPS SBAS GLONASS
```

Factory default

The factory default configuration can always be used to reset the LT-300 GNSS Receiver back to the default configuration and originally starting point.

Factory Default			
Configuration	Options	Default	Comments
Factory default	Activate	See <i>Configuration on page 26</i>	lt>factory default

TABLE 10: LT-500 AHRS FACTORY DEFAULT.

After the factory default configuration has been activated, the user configurations will be deleted and default configuration will be restored.

MMI Description

LED Color Description

The color code and description of the 2-color LED is illustrated in Table 11.

LT-300 GNSS LED Color Description	
LED	Description
Green	Power on unit.
Red	Power on Unit. Error or warnings present. Check installation setup and <i>Troubleshooting</i> on page 32 to resolve the problem. Connect the LT-Service Tool to read-out details from the LT-300 GNSS Receiver, see <i>Connecting LT-Service Tool</i> on page 24.
Off	No power on unit.

TABLE 11: LT-300 GNSS RECEIVER LED COLOR CODE AND DESCRIPTION

The 2-color LED placement on the LT-300 GNSS Receiver is illustrated on Figure 42.

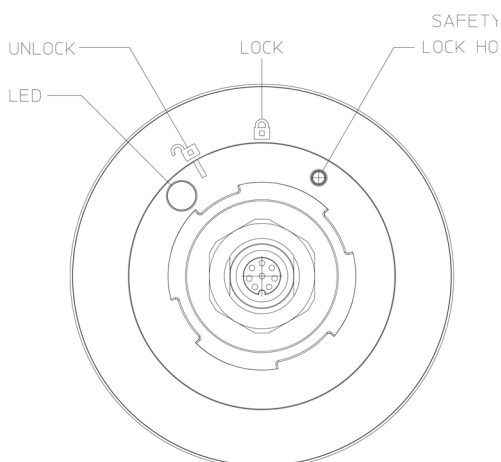

FIGURE 42: LT-300 GNSS RECEIVER 2-COLOR LED PLACEMENT

LT-Service Tool

The LT-Service Tool is a PC program interfacing and communicating with LT-Navigation devices. The LT-Service Tool is communicating via the NMEA 0183 serial interface. The newest available LT-Service Tool will be available from the local dealer or distributor, see www.thrane.eu (Dealers & Distributors).

File name: LT-Service_vX.XX.exe

NOTE: The LT-Service Tool is an optional PC program, which can be used together with the LT-300 GNSS Receiver. It is possible to install the LT-300 GNSS Receiver and use it for navigational purposes, without configuration by the LT-Service Tool. The LT-Service Tool is intended for installation and service by trained personnel.

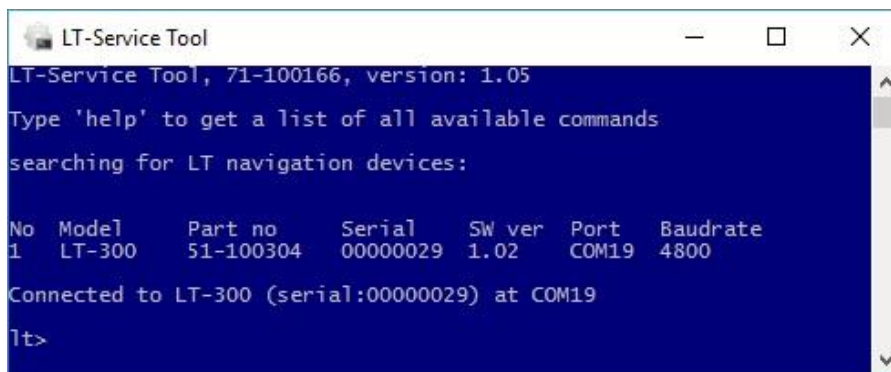

FIGURE 43: THE LT-SERVICE TOOL WILL AUTOMATICALLY SEARCH FOR LT-NAVIGATION DEVICES, WHICH ARE CONNECTED TO THE PC. A MANUAL CONNECTION MODE IS ALSO AVAILABLE.

Identify a LT-Navigation device

The LT-Service Tool requires a bi-directional RS-422 balanced or RS-232 unbalanced serial interface in order to communicate with the LT-Navigation devices. The baud-rate is either: 4800 or 38400 baud (see *NMEA 0183 Baud rate* on page 26).

NOTE: It is recommended to use a ‘USB to RS-422 converter’ for easy interfacing in-between the PC (LT-Service Tool) and the LT-300 GNSS Receiver. Interconnection diagrams are illustrated in *Connecting LT-Service Tool* on page 24.

Automatic mode:

- Step 1: Double click on the LT-Service_vX.XX.exe file to start the program
- Step 2: The LT-Service Tool will automatically search all COM ports on the PC to identify potential LT-Navigation devices connected to the PC. Devices found, will be shown in a list, as illustrated in Figure 43.
- Step 3: If the LT-Service Tool finds more than one LT-Navigation device, then type the number of the device in the list to be connected with, e.g. “1” and “Return”. If only one device is found, then the LT-Navigation device will automatically connect.

Manual mode:

- Step 1: Start cmd.exe (Windows command prompt).
- Step 2: Navigate to the directory where the LT-Service Tool is stored.
- Step 3: In the cmd prompt write: "LT-Service_vX.XX.exe -p COM25 -b 4800" to launch the program (depends on the version of the LT-Service Tool (X.XX = 1.01), PC COM port, and the baud rate for which the LT-300 GNSS Receiver is configured).

LT-Service Tool functions

The LT-Service Tool functions and commands are divided into three main groups:

- **SETUP** The setup commands can be used for configuration of installation parameters. The configurations are described in *Configuration* on page 26.
- **UTILITIES** The utilities commands are related to the navigation status of the unit, especially verification of NMEA 0183 sentences.
- **SYSTEM** The system commands are supporting general support related issues e.g. upload of firmware, configuration status, health status of unit, etc.

List of commands

All available commands in the LT-Service Tool are described in details when using the "help" command, see *App. F – LT-Service Tool* on page 42.

Some of the most used commands are presented here:

"help"	Lists all commands supported by the LT-Service Tool and the LT-300 GNSS
"gnss receiver"	Select the following type of satellites: GPS, SBAS, GLONASS or BeiDou
"nmea2000 bus"	Set NMEA 2000 bus termination: open or close
"nmea0183 sentences"	Configuration of NMEA 0183 sentences (enable/disable)
"diag"	Generate a Diagnostic Report
"upload <filename>"	Upload a new application image (absolute or relative file path)
"reboot"	Reboot device (for configuration to take affect)
"post", "event" & "status"	Prints Power On Self-Tests (POST), events (CM) and status

Troubleshooting

Before contacting the distributor or dealer for support, please check the following troubleshooting guide.

Troubleshooting guide:

- 1) Power cycle the unit to verify that the problem still exists
- 2) Is the communication cable properly connected?
For more information on connecting cables, see *Connecting* on page 20.
- 3) Check the status of the 2-color LED.
If everything is correct, then LED shall light with a green color.
For further details on the LED, see *LED Color Description* on page 29.
- 4) If using NMEA 0183:
 - a. Check the configuration of the NMEA 0183 baud rate.
NMEA 0183: 4800 or 38400 baud (RxD+/RxD- floating: 4800 baud)
For further details on baud rate, see *NMEA 0183 Baud rate* 26.
 - b. Check your navigation equipment for correct baud rate. Check that the LT-300 GNSS Receiver is supporting the expected NMEA 0183 Sentences; see *App. D - NMEA 0183 Sentences* on page 39.
 - c. Verify the NMEA 0183 sentences configuration (enable/disable). The configuration of NMEA 0183 sentences are described in *NMEA 0183 Sentences* on page 26.
- 5) If using NMEA 2000:
 - a. Check the configuration of the NMEA 2000 termination.
NMEA 2000: 'Open' or 'Terminated' (factory default: 'Open')
For further details on the NMEA 2000 termination, see *NMEA 2000 Termination* on page 27.
 - b. Check your navigational equipment for correct selection of the LT-300 GNSS Receiver as preferred source (GPS/GNSS). Check that the LT-300 GNSS Receiver is supporting the expected NMEA 2000 PGNs; see *App. E - NMEA 2000 PGNs* on 41.
- 6) If using the LT-Service Tool:

If any configuration has been applied in the LT-Service Tool, make sure that you have used the "reboot" command and check that the new configuration is properly configured after the LT-300 GNSS Receiver has power up again.
- 7) Connect the LT-Service Tool, see *Connecting LT-Service Tool* on page 24 and *LT-Service Tool* on page 29. Check and record the following commands in the LT-Service Tool:
 - a. Write "status" and check for errors and warnings
 - b. Write "nav" and verify navigation data is as expected
 - c. Write "mon" to monitor NMEA 0183 output
 - d. Write "stat" to evaluate the NMEA 0183 output

- 8) Use the “factory default” command, to reset any configurations back to default. This command can be activated from the LT-Service Tool, see *Factory default* on page 28.

If none of these troubleshooting steps have re-solved the problem, please contact your local distributor or dealer for further action and support.

NOTE: It is recommended, that the end-user makes contact to the local distributor or dealer for technical support on the product, as they have information and experience with the product.

Service and repair

This section describes what the end-user must do in case of required service or repair.

NOTE: The LT-300 GNSS Receiver does not require any scheduled maintenance or service. Make sure that the product is installed, as described in this manual, before making contact to the distributor or dealer for further assistance.

For troubleshooting the LT-300 GNSS Receiver, see *Troubleshooting* on page 32.

If the LT-300 GNSS Receiver for some reason does not work as described in this manual, make contact to the distributor or dealer, from where the product was originally bought. The distributors or dealers will have experience and know-how to assist with further technical support and troubleshooting.

Contacting the distributor/dealer:

- 1) Make sure to have the product name (LT-300 GNSS Receiver), Part Number (P/N: 51-100304), and the unit serial number (S/N: XXXXXXXX) identified. The unit serial number is listed on the outside of the device (pole mount). Alternatively, use the LT-Service Tool to read-out the S/N.
- 2) Write a technical report about the observation or error. If possible, attach a picture of the installed product and include a wiring diagram. If possible, make a diagnostic report with the LT-Service Tool (see *LT-Service Tool* on page 30).
- 3) Send all information to the local distributor or dealer.

IMPORTANT: Unless otherwise agreed, the end-user shall always coordinate service and repair issues directly with the distributor or dealer. This practice also applies for returning of products for service and repair.

All information that will get back to Lars Thrane A/S, either directly or indirectly, will be handled with confidentiality. End-user sensitive data will not be shared with any third party without prior written acceptance from the involved parties.

App. A - Outline Drawings

LT-300 GNSS Receiver with Pole Mount

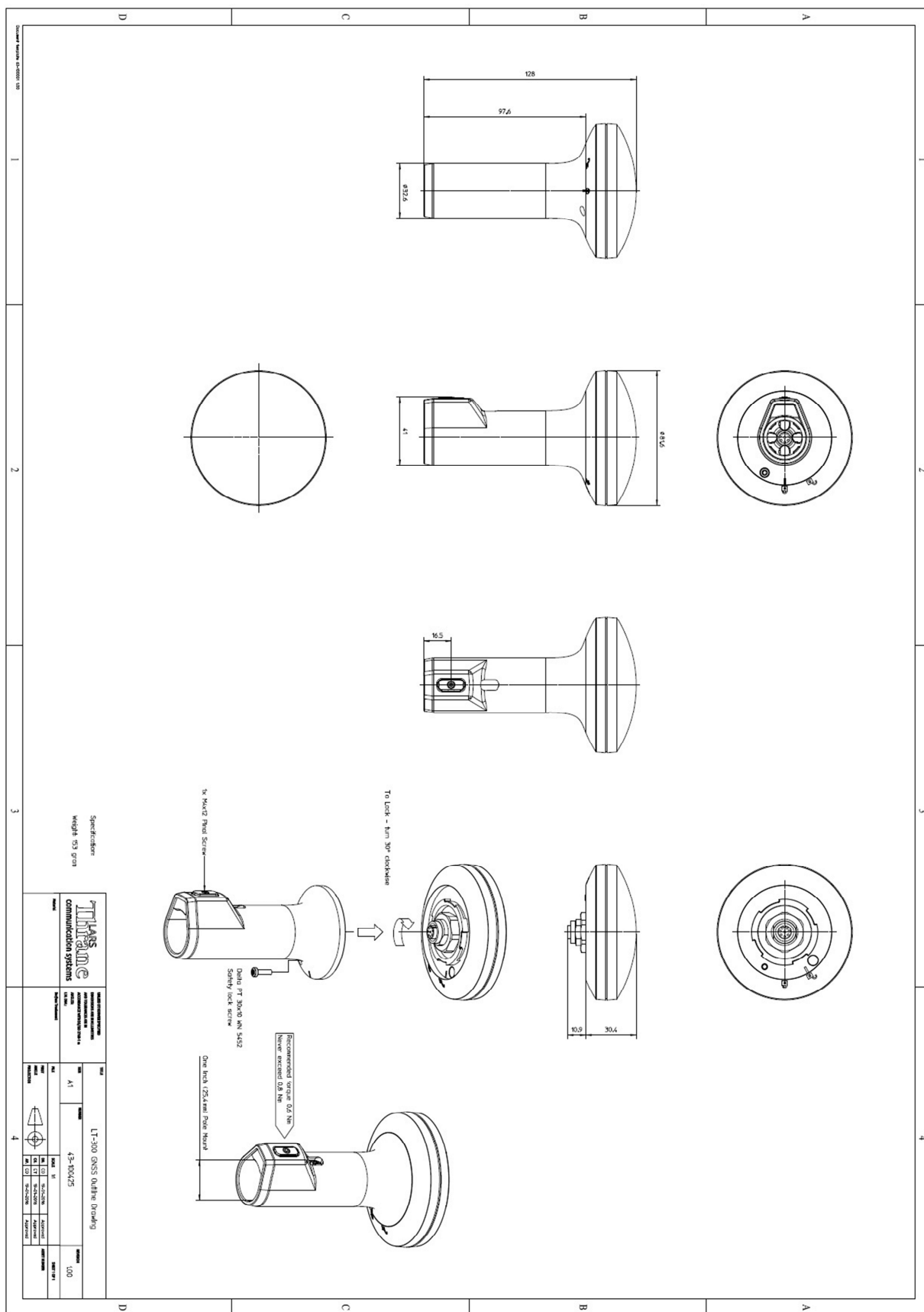

FIGURE 44: LT-300 GNSS RECEIVER OUTLINE DRAWING (POLE MOUNT)

LT-300 Roof Mount

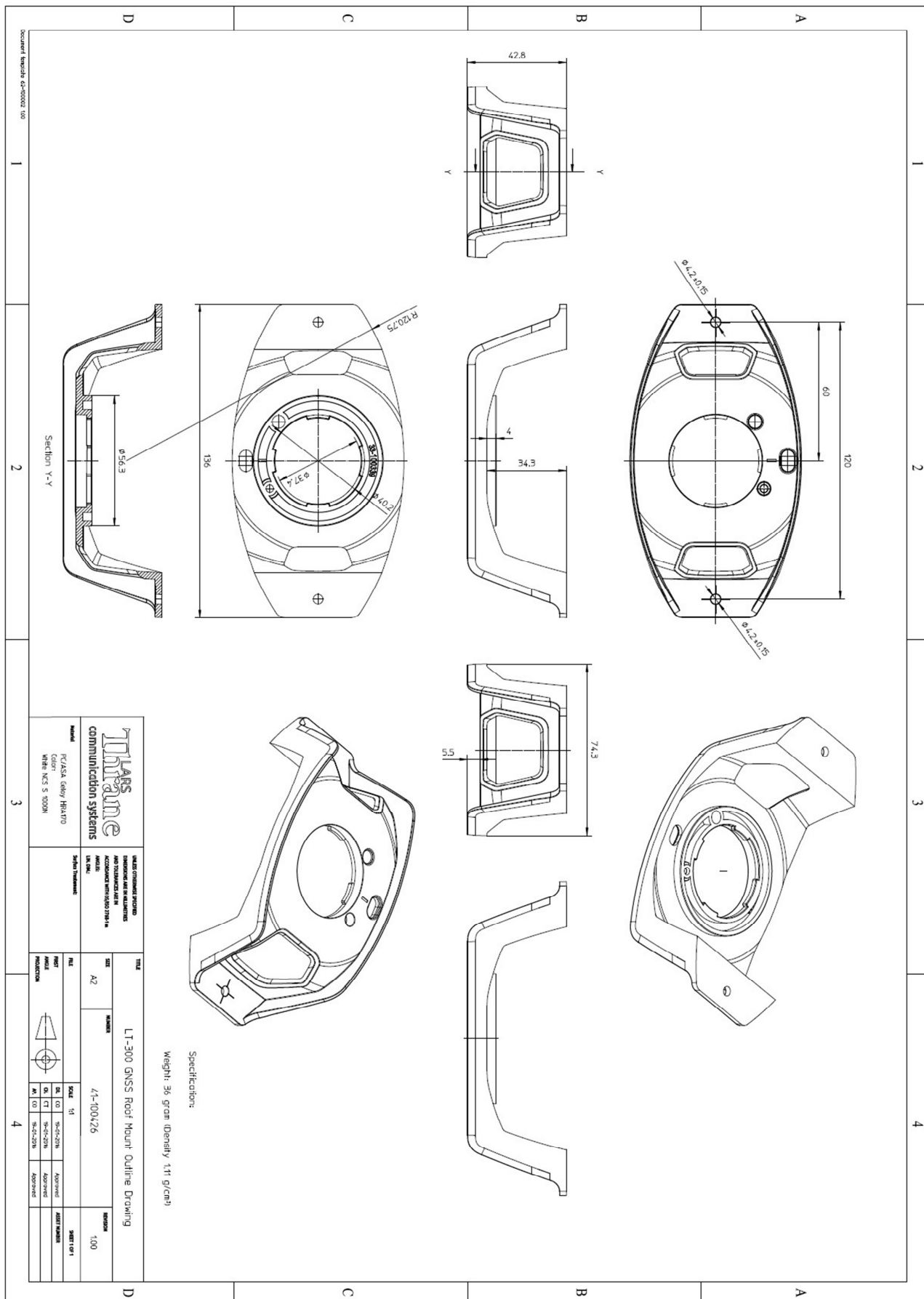

FIGURE 45: LT-300 GNSS RECEIVER OUTLINE DRAWING (ROOF MOUNT)

App. B - Performance

LT-300 GNSS Receiver¹			
Data	Accuracy	Resolution	Range/Comments
Position ²	GNSS: < 2.5 m SBAS: < 2 m	0.1 m	CEP, 50%, 24 hours static, -130 dBm, > 6 SVs By default the GNSS receiver is configured for GPS/GLONASS & SBAS reception Time-To-First-Fix (cold acquisition): 26 s. Time-To-First-Fix (hot acquisition): 1 s.
Speed	0.1 knot	0.1 knot	0 to 195 knots

1: The LT-300 GNSS Receiver performance may be subject to degradation caused by an improper installation.

2: The LT-300 GNSS Receiver has an immunity filter against Iridium and Inmarsat transceivers.

App. C – Specifications

LT-300 GNSS Receiver Specifications	
Certification and standards ¹	CE, IEC 60945, IEC 60950-1/-22, EN 300 440, EN 301 389, FCC, IC, RCM (C-Tick), RoHS NMEA 0183, NMEA 2000
Equipment class	Protected, according to IEC 60945
Weight, with pole mount	153 g (0.34 lbs)
Weight, with roof mount	148 g (0.33 lbs)
Dimensions, with pole mount	∅ 81.6 x 128.0 mm (∅ 3.21 x 5.04 in)
Dimensions, with roof mount	136.0 x 81.6 x 45.2 mm (5.35 x 3.21 x 1.78 in)
Temperature, operational (ambient)	-40°C to +55°C (-40°F to +131°F)
Temperature, storage (ambient)	-40°C to +85°C (-40°F to +185°F)
Vibration, operational	IEC 60945 (sine) & Proprietary Maritime Random profile (240 h)
Vibration, survival	Proprietary Maritime Random profile (100 h)
Vibration, shock	Proprietary Maritime profile (100 g pk, 11 ms)
Waterproof rating	IP67
Humidity	95% non-condensing @ 40°C
Wind, operational	80 knots (93 MPH)
Wind, survival	110 knots (127 MPH)
Ice, survival	25 mm (1 in)
Solar radiation	1120 W/m ²
Communication interface	8-pin female connector for NMEA 0183, NMEA 2000 and power
Input voltage	9-40 VDC
Power consumption	< 1 W (@ 12 VDC)
Load Equivalent Number (LEN)	2
Compass safe distance standard	0.3 m (1 ft)
Compass safe distance steering	0.3 m (1 ft)
Mounting, pole mount	25.4 mm (1 in)
Warranty	2 year
Maintenance	None

App. D - NMEA 0183 Sentences

The LT-300 GNSS Receiver is compliant with version 4.00 of the NMEA 0183 standard. The following table lists the supported sentences.

NMEA 0183 Sentences		
Sentence	Description	Rate
4800 baud		
GNDTM	Datum Reference	1 Hz
GNGGA	GPS Fix Data	1 Hz
GNGLL	Position Latitude/Longitude WGS84	1 Hz
GNGSA	GNSS DOP and Active Satellite	1 Hz
GNRMC	Mini Specific GNSS Data	1 Hz
GNVTG	Course Over Ground and Ground Speed	1 Hz
GNZDA	Time and Date	1 Hz
38400 baud		
GNDTM	Datum Reference	1 Hz
GNGGA	GPS Fix Data	1 Hz
GNGLL	Position Latitude/Longitude WGS84	1 Hz
GNGSA	GNSS DOP and Active Satellite	1 Hz
GNRMC	Mini Specific GNSS Data	1 Hz
GNVTG	Course Over Ground and Ground Speed	1 Hz
GNZDA	Time and Date	1 Hz
GPGSV ¹	GNSS Satellites in View	1 Hz

Note: For all GNSS sentences, talker ID "GN" can be configured to be "GP"

1: Talker ID (GP, GL, GB) depends on satellite system (GPS/SBAS, GLONASS, BeiDou)

GNSS Talker Identifier

The first two characters in the address field of an NMEA 0183 sentence is the Talker Identifier (e.g. “GN” in the address field “GNRMC”). The Talker Identifier may be used to determine the source of a sentence, when it can have multiple sources. In case of the GNSS related sentences (DTM, GGA, GLL, GSA, GSV, RMC, VTG, ZDA), the Talker Identifier can be used to determine from which specific GNSS system the data originates:

GNSS Talker Identifier	
Talker Identifier	GNSS Type
GB	BeiDou
GL	GLONASS
GN	Multiple GNSS'
GP	GPS, SBAS, or QZSS

TABLE 12: GNSS TALKER IDENTIFIER

GN Talker Identifier is a special case that indicates the sentence data originates from multiple GNSS systems. This is the case when the LT-300 is configured (see *GNSS Receiver* on page 27) to use multiple GNSS systems: GPS + GLONASS or GPS + BeiDou.

The GSV sentence will never be sent with Talker Identifier GN as it will ever only contain data from one GNSS system. If the LT-300 GNSS Receiver is configured to use multiple GNSS systems, the GSV sentence will be repeated for each GNSS system and the Talker Identifier of each GSV sentence will indicate the specific GNSS system to which it applies.

App. E - NMEA 2000 PGNs

The LT-300 GNSS Receiver is compliant with version 2.000 of the NMEA 2000 standard and version 2.000 of the NMEA Network Database. The following table lists the supported PGNs.

NMEA 2000 PGNs		
PGN	Description	Rate
Periodic PGNs		
126992	System Time	1 Hz
126993	Heartbeat	< 0.1 Hz
127258	Magnetic Variation	1 Hz
129025	Position, Rapid Update	10 Hz
129026	COG & SOG, Rapid Update	4 Hz
129029	GNSS Position Data	1 Hz
129044	Datum	0.1 Hz
129539	GNSS DOPs	1 Hz
129540	GNSS Sats in View	1 Hz
Requestable PGNs		
126464	PGN List (Transmit and Receive)	-
126996	Product Information	-
129538	GNSS Control Status	-
Other PGNs		
059392	ISO Acknowledgement	-
059904	ISO Request	-
060928	ISO Address Claim	-
126208	NMEA Request/Command/Acknowledge	-

App. F – LT-Service Tool (commands)

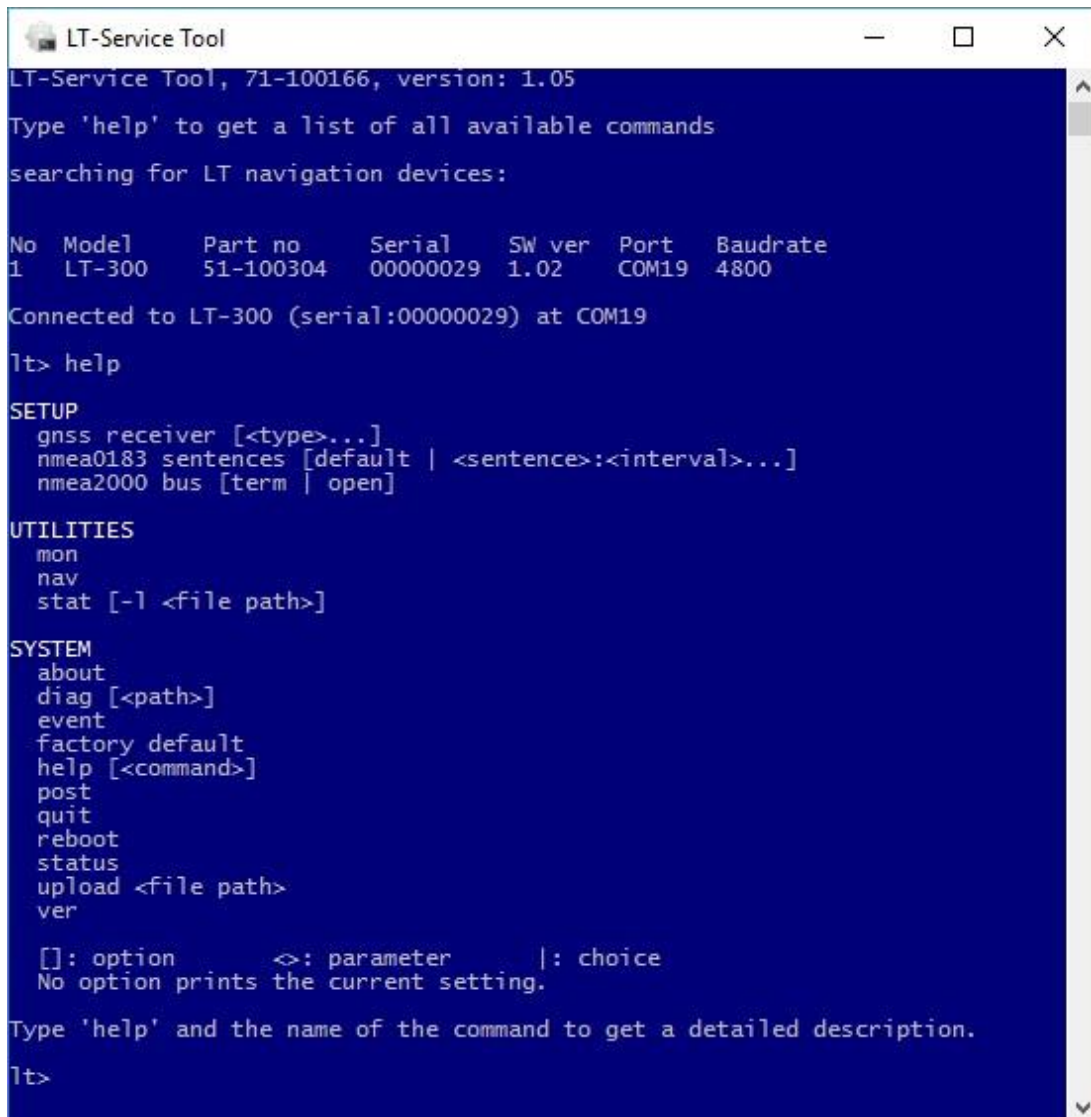

```
LT-Service Tool
LT-Service Tool, 71-100166, version: 1.05
Type 'help' to get a list of all available commands
searching for LT navigation devices:

No  Model   Part no   Serial    SW ver   Port   Baudrate
1   LT-300   51-100304 00000029  1.02    COM19  4800

Connected to LT-300 (serial:00000029) at COM19
lt> help

SETUP
gnss receiver [<type>...]
nmea0183 sentences [default | <sentence>:<interval>...]
nmea2000 bus [term | open]

UTILITIES
mon
nav
stat [-l <file path>]

SYSTEM
about
diag [<path>]
event
factory default
help [<command>]
post
quit
reboot
status
upload <file path>
ver

[: option      <>: parameter      |: choice
No option prints the current setting.

Type 'help' and the name of the command to get a detailed description.
lt>
```

FIGURE 46: LT-SERVICE TOOL SCREEN DUMP (HELP COMMAND OUTPUT).

App. G - Declaration of Conformity

68-100429 Rev. 1.00	
Declaration of Conformity	
This declaration of conformity is issued under the sole responsibility of the manufacturer	
Manufacturer:	Lars Thrane A/S
Address:	Stubbeled 2, 2950 Vedbæk, Denmark
Product Identification:	LT-300 GNSS Receiver PN = 51-100304
Product Description	
The LT-300 GNSS Receiver is capable of providing accurate positions down to 2 meters. The LT-300 GNSS Receiver outputs navigation data (up to 10 Hz): UTC time and date, position, course over ground, speed over ground, GNSS satellite information and magnetic variation.	
The 72-channel GNSS receiver supports multiple satellite systems: GPS, GPS & GLONASS or GPS & BeiDou including Satellite-Based Augmentation System SBAS: EGNOS, WAAS and MSAS.	
The LT-300 GNSS Receiver is designed and built for the extremely demanding and rough environment at sea and with an operational temperature (ambient) range from -40°C and +55°C (-40°F and +131°F).	
Declaration	
We as manufacturer declare that the above listed product complies with the specification of the EC directive 1999/5/EC. The conformity has been assessed according to the procedure detailed in Annex IV of the R&TTE Directive. The following harmonized standards were applied:	
RF Spectrum:	EN 300 440-2, v1.4.1
EMC:	EN 301 489-1, v1.9.2 / EN 301 489-3, v1.6.1
Safety:	EN 60950-1:2006+AC:2011+A11:2009+A1:2010+A12:2011+A2:2013 EN 60950-22:2005 EN 60945:2002
Year of affixing the CE mark: 2016	
Place and Date	
Vedbæk, 18. Marts 2016	
	
Peter Thrane, CEO	
Lars Thrane A/S	
	
Lars Thrane A/S	www.thrane.eu

FIGURE 47: LT-300 GNSS RECEIVER DECLARATION OF CONFORMITY.

Lars Thrane A/S

Stubbeled 2

2950 Vedbæk

Denmark

www.thrane.eu